

RACCORDS A SOUDER WELDING FITTINGS



raccords / fittings

pressions et essais hydrauliques <i>pressures and hydrostatic testing</i>	2-3
tolérances et parachèvements <i>tolerances and ends preparation</i>	2-4

- aciers au carbone / *carbon steels*
- aciers basse température / *low temperature steels*
- aciers alliés / *alloys steel*

ASTM spécifications / <i>specifications</i>	2-10
coudes / <i>elbows</i>	2-12
tés / <i>tees</i>	2-28
caps / <i>caps</i>	2-62
réductions / <i>reducers</i>	2-66

- aciers inoxydables / *stainless steels*

ASTM tolérances et spécifications <i>tolerances and specifications</i>	2-90
coudes / <i>elbows</i>	2-94
tés / <i>tees</i>	2-104
caps / <i>caps</i>	2-116
réductions / <i>reducers</i>	2-118
collets / <i>lap joints «stub end»</i>	2-126

pressions intérieures maxima d'utilisation des raccords

maximum internal working pressures for fittings



Les pressions d'utilisation des raccords fabriqués suivant la norme ASME B 16.9-1993 peuvent être calculées comme celles des tuyaux droits sans soudure, en utilisant les règles des codes ASME B 31 pour les tuyauteries sous pression.

The allowable pressure ratings for fittings designed in accordance with the standard ASME B 16.9-1993 may be calculated as for straight seamless pipe in accordance with the rules established in the applicable section of the ASME B 31 codes for pressure piping.

ASME B 31.4	Tuyauterie de transport de liquides pour hydrocarbures, gaz liquéfiés, ammoniaque et alcools	Liquid transportation systems for hydrocarbons, liquid petroleum gas, anhydrous ammonia and alcohols
ASME B 31.5	Tuyauterie pour l'industrie du froid	Refrigeration piping
ASME B 31.1	Tuyauterie de transport d'énergie	Power piping
ASME B 31.3	Tuyauterie dans les raffineries de pétrole et les industries chimiques	Chemical plant and petroleum refinery piping
ASME B 31.8	Tuyauterie pour le transport et la distribution du gaz	Gas transmission and distribution piping systems

essais hydrauliques des raccords

hydrostatic testing for fittings

Les essais hydrauliques ne sont pas exigés pour les raccords à souder. Ils doivent toutefois être garantis contre la rupture et pouvoir supporter sans déformation une pression d'essai hydraulique égale à celle d'un tube de caractéristiques et de dimensions équivalentes.

Hydrostatic testing of wrought fittings is not required by this Standard. All fittings shall be capable of withstanding, without leakage or impairment of serviceability, a hydrostatic test pressure required by the applicable piping code for seamless pipe of material equivalent to the fitting material and of the NPS and wall thickness the fitting marking identifies.



coudes court rayon

ASME B 16.28 - 1994

tolérances dimensionnelles

Diamètre nominal du tube NPS	Tous raccords			Coudes 90°		Coudes 180°	
	Diamètre extérieur au chanfrein (1) (2)	Diamètre intérieur à l'extrémité (1) (3) (4)	Épaisseur (3)	Dimensions centre-à-extrémité A	Dimensions centre-à-centre O	Hauteur hors tout K	Alignement des extrémités U
1/2 à 2 1/2	+ 1,6 - 0,8	± 0,8	Pas plus petite que 87,5 % de l'épaisseur nominale marquée sur le raccord	± 1,6	± 6,35	± 6,35	± 0,8
3 à 4	± 1,6	± 1,6		± 1,6	± 6,35	± 6,35	± 0,8
5 à 8	+ 2,3 - 1,6	± 1,6		± 1,6	± 6,35	± 6,35	± 0,8
10 à 18	+ 4,0 - 3,0	± 3,0		± 2,3	± 9,65	± 6,35	± 1,6
20 à 24	+ 6,35 - 4,8	± 4,8		± 2,3	± 9,65	± 6,35	± 1,6

Dimensions en mm (sauf diamètre nominal du tube).

- (1) L'ovalisation est la somme des valeurs absolues des tolérances plus et moins.
- (2) Cette tolérance peut être dépassée localement compte tenu des variations possibles de l'épaisseur suivant la technique de construction du raccord.
- (3) Le diamètre intérieur et l'épaisseur nominale aux extré-

- mités doivent être indiqués par le client. La tolérance d'épaisseur s'applique à l'ensemble du raccord.
- (4) Sauf spécification contraire de l'acheteur, ces tolérances s'appliquent au diamètre intérieur nominal qui est égal à la différence entre le diamètre extérieur nominal et deux fois l'épaisseur nominale.

Diamètre nominal du tube NPS	Tolérance angulaire	
	Perpendicularité Q	Travers P
1/2 à 4	± 0,8	± 1,6
5 à 8	± 1,6	± 3,0
10 à 12	± 2,3	± 4,8
14 à 16	± 2,3	± 6,35
18 à 24	± 3,0	± 9,65

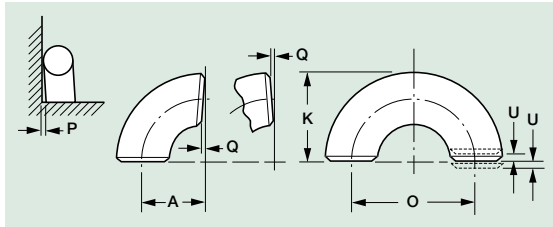

parachèvement des extrémités

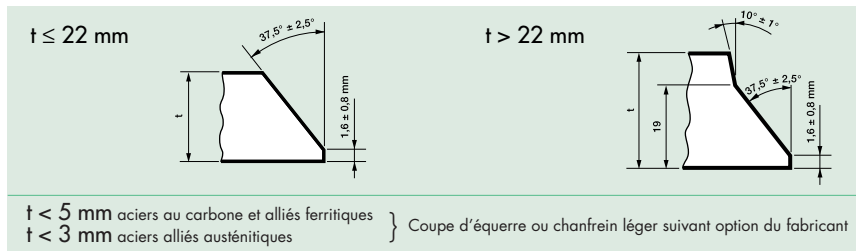

short radius elbows and returns

ASME B 16.28 - 1994

size tolerances

Nominal pipe size NPS	All fittings			90-Deg elbows	180-Deg returns		
	Outside diameter at bevel (1) (2)	Inside diameter at end (1) (3) (4)	Wall thickness (3)	Center-to-end dimension A	Center-to-center dimension O	Back-to-face dimension K	Alignement of ends U
1/2 to 2 1/2	+ 0.06 - 0.03	± 0.03	Not less than 87.5 % of nominal thickness marked on fitting	± 0.06	± 0.25	± 0.25	± 0.03
3 to 4	± 0.06	± 0.06		± 0.06	± 0.25	± 0.25	± 0.03
5 to 8	+ 0.09 - 0.06	± 0.06		± 0.06	± 0.25	± 0.25	± 0.03
10 to 18	+ 0.16 - 0.12	± 0.12		± 0.09	± 0.38	± 0.25	± 0.06
20 to 24	+ 0.25 - 0.19	± 0.19		± 0.09	± 0.38	± 0.25	± 0.06

Dimensions in inches

- (1) Out-of-round is the sum of absolute values of plus and minus tolerances.
- (2) This tolerance may be exceeded in localized areas of formed fittings where increased wall thickness is required to meet design requirements in the ASME B 16.28.
- (3) The inside diameter and the nominal wall thicknesses at

- ends are to be specified by the purchaser. Wall thickness tolerance applies throughout the fitting.
- (4) Unless otherwise specified by the purchaser, these tolerances apply to the nominal inside diameter, which equals the difference between the nominal outside diameter and twice the nominal wall thickness.

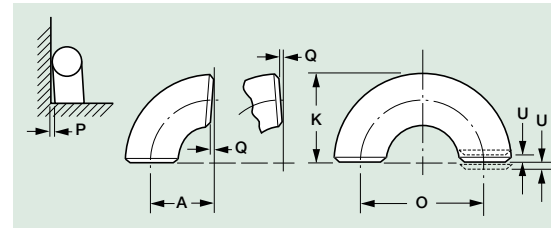

Nominal pipe size NPS	Angularity tolerance	
	Off angle Q	Off plane P
1/2 to 4	± 0.03	± 0.06
5 to 8	± 0.06	± 0.12
10 to 12	± 0.09	± 0.19
14 to 16	± 0.09	± 0.25
18 to 24	± 0.12	± 0.38

ends preparation

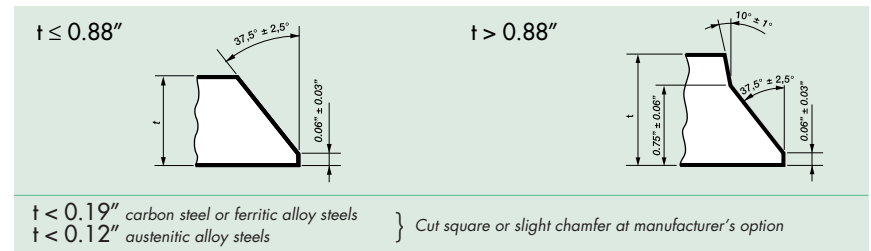

coudes LR – tés – réductions – caps – collets

ASME B 16.9 – 1993

tolérances dimensionnelles

Diamètre nominal du tube NPS	Tous raccords			Coudes LR 90° et 45° et tés	Réductions et collets pour brides tournantes	Caps	Coudes LR 180°		
	Diamètre (1) (2) extérieur au chanfrein D	Diamètre intérieur à l'extrémité (1) (3) (4)	Épaisseur (3) t	Dimensions centre-à-extrémité A - B - C - M	Longueur hors tout F - H	Longueur hors tout E	Dimensions centre-à-centre O	Hauteur hors tout K	Alignement des extrémités U
1/2 à 2 1/2	+ 1,6 - 0,8	± 0,8	Pas plus petite que 87,5 % de l'épaisseur nominale	± 1,6	± 1,6	± 4	± 6,35	± 6,35	± 0,8
3 à 4	± 1,6	± 1,6		± 1,6	± 1,6	± 4	± 6,35	± 6,35	± 0,8
5 à 8	+ 2,3 - 1,6	± 1,6		± 1,6	± 1,6	± 6,35	± 6,35	± 6,35	± 0,8
10 à 18	+ 4,0 - 3,0	± 3,0		± 2,3	± 2,3	± 6,35	± 9,65	± 6,35	± 1,6
20 à 24	+ 6,35 - 4,8	± 4,8		± 2,3	± 2,3	± 6,35	± 9,65	± 6,35	± 1,6
26 à 30	+ 6,35 - 4,8	± 4,8		± 3,0	± 4,8	± 9,65			
32 à 48	+ 6,35 - 4,8	± 4,8		± 4,8	± 4,8	± 9,65			

Dimensions en mm (sauf diamètre nominal du tube).

- (1) L'ovalisation est la somme des valeurs absolues des tolérances plus et moins.
- (2) Cette tolérance peut être dépassée localement compte tenu des variations possibles de l'épaisseur suivant la technique de construction du raccord.
- (3) Le diamètre intérieur et l'épaisseur nominale aux extrémités doivent être indiqués par le client.
- (4) Sauf spécification contraire de l'acheteur, ces tolérances s'appliquent au diamètre intérieur nominal qui est égal à la différence entre le diamètre extérieur nominal et deux fois l'épaisseur nominale.

Diamètre nominal du tube NPS	Tolérance angulaire	
	Perpendicularité Q	Travers P
1/2 à 4	± 0,8	± 1,6
5 à 8	± 1,6	± 3,0
10 à 12	± 2,3	± 4,8
14 à 16	± 2,3	± 6,35
18 à 24	± 3,0	± 9,65
26 à 30	± 4,8	± 9,65
32 à 42	± 4,8	± 12,70
44 à 48	± 4,8	± 19,05

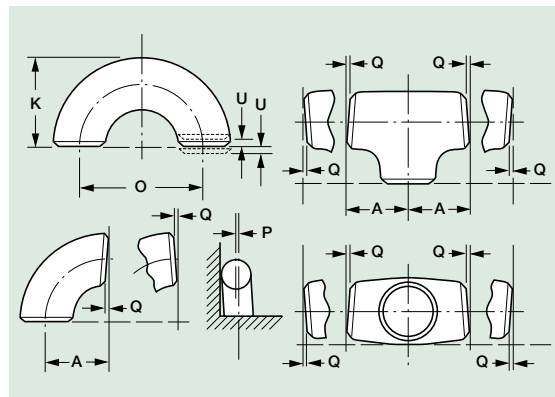

LR elbows – tees – reducers – caps – stub ends

ASME B 16.9 – 1993

size tolerances

Nominal pipe size NPS	All fittings			90-Deg and 45-Deg LR elbows and tees	Reducers and lap-joint stub ends	Caps	180-Deg LR returns		
	Outside (1) (2) diameter at bevel D	Inside diameter at end (1) (3) (4)	Wall thickness (3) t	Center-to-end dimension A - B - C - M	Overall length F - H	Overall length E	Center-to-center dimension O	Back-to-face dimension K	Alignment of ends U
1/2 to 2 1/2	+ 0.06 - 0.03	± 0.03	Not less than 87.5 % of nominal thickness	± 0.06	± 0.06	± 0.12	± 0.25	± 0.25	± 0.03
3 to 4	± 0.06	± 0.06		± 0.06	± 0.06	± 0.12	± 0.25	± 0.25	± 0.03
5 to 8	+ 0.09 - 0.06	± 0.06		± 0.06	± 0.06	± 0.25	± 0.25	± 0.25	± 0.03
10 to 18	+ 0.16 - 0.12	± 0.12		± 0.09	± 0.09	± 0.25	± 0.38	± 0.25	± 0.06
20 to 24	+ 0.25 - 0.19	± 0.19		± 0.09	± 0.09	± 0.25	± 0.38	± 0.25	± 0.06
26 to 30	+ 0.25 - 0.19	± 0.19		± 0.12	± 0.19	± 0.38			
32 to 48	+ 0.25 - 0.19	± 0.19		± 0.19	± 0.19	± 0.38			

Dimensions in inches.

- (1) Out-of-round is the sum of absolute values of plus and minus tolerance.
- (2) This tolerance may be exceeded in localized areas of formed fittings where increased wall thickness is required to meet design requirements of § 2.2 to ASME B 16.9.
- (3) The inside diameter and the nominal wall thicknesses at ends are to be specified by the purchaser.
- (4) Unless otherwise specified by the purchaser, these tolerances apply to the nominal inside diameter, which equals the difference between the nominal outside diameter and twice the nominal wall thickness.

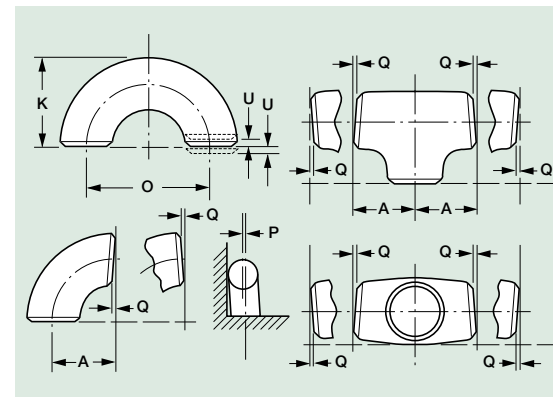

Nominal pipe size NPS	Angularity tolerance	
	Off angle Q	Off plane P
1/2 to 4	± 0.03	± 0.06
5 to 8	± 0.06	± 0.12
10 to 12	± 0.09	± 0.19
14 to 16	± 0.09	± 0.25
18 to 24	± 0.12	± 0.38
26 to 30	± 0.19	± 0.38
32 to 42	± 0.19	± 0.50
44 to 48	± 0.19	± 0.75



coudes LR – tés réductions – caps

LR elbows – tees reducers – caps

ASME B 16.9 – 1993

parachèvement des extrémités

ends preparation

PRÉPARATION DES EXTRÉMITÉS

Coupe d'équerre ou chanfrein léger à l'option du fabricant pour :

- $t \leq 5$ mm aciers au carbone ou alliés ferritiques
- $t \leq 3$ mm aciers austénitiques

ENDS PREPARATION

Cut square or slight chamfer, at manufacturer's option for :
 $t \leq 0.19$ " carbon steel or ferritic alloy steels
 $t \leq 0.12$ " austenitic alloy steels

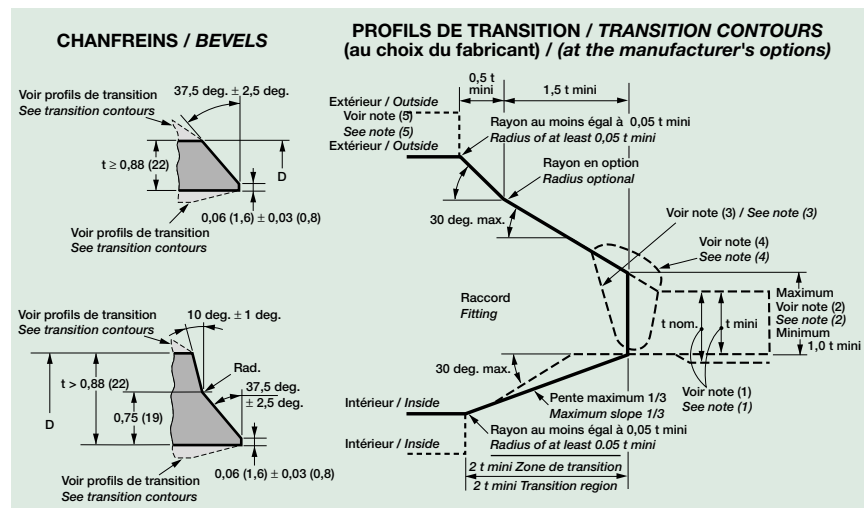

Notes :

- La valeur de t mini applicable est l'une ou l'autre des suivantes :
 - l'épaisseur minimum du tube commandé,
 - 0,875 fois l'épaisseur nominal d'un tube suivant schéma et qui a une tolérance d'épaisseur de $-12,5\%$.
- L'épaisseur maximum à l'extrémité du raccord est :
 - la plus grande de (t mini + 0,16") ou 1,15 t mini en cas de commande basée sur une épaisseur minimum,
 - la plus grande de (t mini + 0,16") ou 1,10 t nom. en cas de commande basée sur une épaisseur nominale.
- Le chanfrein n'est donné qu'à titre d'exemple.
- La soudure de renforcement permise par l'application des codes peut s'étendre au-delà de l'enveloppe maximale.
- Quand les profils de transition utilisant la pente maximale sans intersection avec la surface extérieure, comme montré par la ligne en pointillés, les pentes maximale indiquées avec leurs chanfreins respectifs seront utilisés.

Notes :

- The value of t mini is whichever of the following is applicable :
 - the minimum ordered wall thickness of the pipe,
 - 0.875 times the nominal wall thickness of pipe ordered to a pipe schedule wall thickness that has an under tolerance of 12.5 %.
- The maximum thickness at the end of the component is :
 - the greater of (t mini + 0.16") or 1.15 t mini when ordered on a minimum wall basis,
 - the greater of (t mini + 0.16") or 1.10 t nom. when ordered on a nominal wall basis.
- Weld bevel is shown for illustration only.
- The weld reinforcement permitted by applicable code may lie outside the maximum envelope.
- Where transitions using maximum slope do not intersect outside surface within the transition region, as shown by phantom outline, maximum slopes shown shall be used. Alternately, radii lying within the envelope may be used.

RACCORDS

- aciers au carbone
- aciers alliés
- aciers basse température

FITTINGS

- carbon steels
- alloy steels
- steels for low temperature service



Les raccords répondent / Fittings are in strict accordance :

– POUR LES DIMENSIONS / FOR DIMENSIONS :

aux exigences des ASME B 16.9 – 1993 et B 16.28 – 1994 / with ASME B 16.9 – 1993 and B 16.28 – 1994

– POUR L'ACIER / FOR STEEL :

aux exigences de l'ASTM / with ASTM

ACIER AU CARBONE / CARBON STEEL

ASTM A 234 / A 234 M – 96 a			Nuance WPB / Grade WPB (1)	
Composition chimique % Chemical requirements %	C maxi		0,30 (a) (b) (c)	
	Mn		0,29 – 1,06	
	P maxi		0,050	
	S maxi		0,058	
	Si		0,10 mini (b)	
	Cr maxi		0,40 (f) (g)	
	Mo maxi		0,15 (f) (g)	
	Ni maxi		0,40 (f)	
	Cu maxi		0,40 (f)	
	V maxi		0,08	
Caractéristiques mécaniques Mechanical requirements	Résistance rupture – plage Tensile strength – range	MPa ksi	415 – 585 60 – 85	
	Limite élastique minimum Minimum yield strength	MPa ksi	240 35	
Mechanical requirements	Allongement minimum % (sur 2") Elongation (in 2") mini per cent		Long. 30 (2) – Transv. 20 (2) (3)	
	Dureté maximum Maximum hardness		197 HB	

ACIERS ALLIÉS / ALLOY STEELS

ASTM A 234 / A 234 M – 96 a			Nuance / Grade (1)			
			WP 1	WP 11 c l 1	WP 22 c l 1	WP 5
Composition chimique % Chemical requirements %	C		0,28 maxi	0,05 – 0,15	0,05 – 0,15	0,15 maxi
	Mn		0,30 – 0,90	0,30 – 0,60	0,30 – 0,60	0,30 – 0,60
	P maxi		0,045	0,030	0,040	0,040
	S maxi		0,045	0,030	0,040	0,030
	Si		0,10 – 0,50	0,50 – 1,00	0,50 maxi	0,50 maxi
	Cr		—	1,00 – 1,50	1,90 – 2,60	4,00 – 6,00
	Mo		0,44 – 0,65	0,44 – 0,65	0,87 – 1,13	0,44 – 0,65
Caractéristiques mécaniques Mechanical requirements	Résistance rupture – plage Tensile strength – range	MPa ksi	380 – 555 55 – 80	415 – 585 60 – 85		
	Limite élastique minimum Minimum yield strength	MPa ksi	205 30	205 30		
Mechanical requirements	Allongement mini % (sur 2") Elongation (in 2") mini per cent		Long. 30 (2) – Transv. 20 (2)			
	Dureté maximum Maximum hardness		197 HB		217 HB	

ACIERS BASSE TEMPÉRATURE / LOW TEMPERATURE STEELS

Les raccords en acier basse température répondent, pour l'acier, aux exigences de l'ASTM.

For steel, low temperature fittings are in strict accordance with ASTM requirements.

A 420 / A 420 M – 96		Nuance / Grade (1)	
		WPL 6 (c)	WPL 3
Composition chimique % Chemical requirements %	C maxi	0,30	
	Mn	0,60 – 1,35 (d)	
	P maxi	0,035	
	S maxi	0,040	
	Si	0,15 – 0,30	
	Ni	0,40 maxi	
	Cr	0,30 maxi	
	Cu	0,40 maxi	
	Cb	0,02 maxi	
	V	0,05 maxi	
Caractéristiques mécaniques Mechanical requirements	Limite élastique minimum Minimum yield strength	MPa ksi	240 35
	Résistance rupture Tensile strength	MPa ksi	415 – 585 60 – 85
Mechanical requirements	Allong. mini % (sur 2") Elong. (in 2") mini per cent		Long. 30 – Transv. 16,5 (2)
	Essais de flexion par choc Impact test		– 50° F – 45° C
			Long. 30 – Transv. 20 (2)

- (a) 0,35 maxi pour les raccords fabriqués à partir de barre ou de tôle.
 (b) 0,35 maxi de carbone et 0,35 maxi silicium, sans minimum pour les raccords forgés.
 (c) Pour chaque réduction de 0,01 % de la teneur en carbone spécifiée, la teneur en manganèse peut être augmentée de 0,06 % au dessus de 1,06 % sans pouvoir dépasser 1,35 %.
 (d) 1,35 maxi pour les raccords forgés.
 (e) 0,90 maxi pour les raccords fabriqués à partir de tôle ou les raccords forgés.
 (f) la somme de Cu + Ni + Cr + Mo ≤ 1,00 %
 (g) la somme de Cr + Mo ≤ 0,32 %

- (1) Pour les raccords de fabrication soudée, la désignation et le marquage de la nuance seront suivis de la lettre «W».
 (2) Pour épaisseur ≥ 7,94 mm (5/16").
 (3) 17 % pour les raccords en acier au carbone fabriqués à partir de tôles.

Tous les raccords suivant ASTM A 234 ou A 420 – de fabrication soudée – seront radiographiés à 100 %.
 Au lieu d'être radiographiés, les soudures pourront être contrôlées aux ultrasons.

- (a) 0.35 maxi for fittings made from bar or plate.
 (b) 0.35 maxi carbon and 0.35 maxi silicon with no minimum for fittings made from forgings.
 (c) For each reduction of 0.01 % below the specified carbon maxi, an increase of 0.06 % manganese above 1.06 % will be permitted to a maximum of 1.35 % manganese.
 (d) 1.35 maxi for fittings made from forgings.
 (e) 0.90 maxi for fittings made from plate or forgings.
 (f) The sum of Cu + Ni + Cr + Mo ≤ 1.00 %
 (g) The sum of Cr + Mo ≤ 0.32 %

- (1) When fittings are of welded construction, the grade and marking symbol shall be supplemented by the letter «W».
 (2) For wall 5/16" (7.94 mm) and over in thickness.
 (3) 17 % for carbon steel fittings manufactured from plate.

All fusion welded butt welding fittings according to ASTM A 234 or A 420 will be 100 % X-rayed.
 Instead of radiographic examination, welds may be ultrasonically examined.



coudes long rayon à 45°

ASME B 16.9-1993

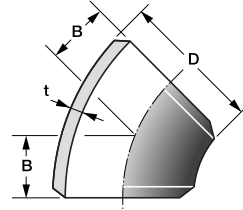

45° long radius elbows

ASME B 16.9-1993

Diamètre Nominal Nominal Pipe Size (NPS)	Dia. extérieur au chanfrein Outside diameter at bevel	Centre-à-extrémité Center-to-end	STD	E.F. X.S.	X.E.F. X.X.S.	SCH 10	SCH 20
Pouces/Inches	D - mm	B - mm	† ép./W.T. mm masse/weight kg				
1/2	21	16	2,77 0,04	3,73 0,08	7,47		
3/4	27	19 (1)	2,87 0,04	3,91 0,08	7,82		
1	33	22	3,38 0,08	4,55 0,10	9,09 0,19		
1 1/4	42	25	3,56 0,12	4,85 0,18	9,70 0,30		
1 1/2	48	29	3,68 0,18	5,08 0,25	10,16 0,45		
2	60	35	3,91 0,32	5,54 0,47	11,07 0,84		
2 1/2	73	44	5,16 0,64	7,01 0,85	14,02 1,60		
3	89	51	5,49 1,02	7,62 1,37	15,24 2,60		
3 1/2	102	57	5,74 1,43	8,08 1,97			
4	114	64	6,02 1,95	8,56 2,70	17,12 5,20		
5	141	79	6,55 3,25	9,52 4,42	19,05 9,08		
6	168	95	7,11 5,10	10,97 7,67	21,95 15,00		
8	219	127	8,18 11,15	12,70 14,95	22,23 27,00	6,35	9,00
10	273	159	9,27 20,50	12,70 24,30	25,40 48,50	6,35	18,50
12	324	190	9,52 27,00	12,70 35,00	25,40 70,80	6,35	24,75
14	356	222	9,52 34,00	12,70 47,17		6,35	7,92 32,00
16	406	254	9,52 48,00	12,70 62,37		6,35	7,92 46,50

(1) La dimension peut être de 11 mm suivant option du fabricant. Les masses indiquées sont approximatives.

SCH 30	SCH 40	SCH 60	SCH 80	SCH 100	SCH 120	SCH 140	SCH 160	Diamètre Nominal Nominal Pipe Size (NPS)
† ép./W.T. mm masse/weight kg								Pouces/Inches
2,41							4,78	1/2
							0,12	
2,41							5,56	3/4
							0,12	
2,90							6,35	1
							0,14	
2,97							6,35	1 1/4
							0,22	
3,18							7,13	1 1/2
							0,33	
3,18	Voir STD		Voir E.F.				8,74	2
							0,70	
4,78							9,52	2 1/2
							1,20	
4,78	Refer to STD		Refer to X.S.				11,13	3
							2,00	
4,78								3 1/2
4,78							11,13	4
							3,47	
							12,70	5
							6,31	
							14,27	6
							9,81	
							14,00	
7,03		10,31		15,09	18,26	20,62	23,01	8
10,35		13,34		19,07	21,59	26,00	29,00	
7,80		Voir E.F.	15,09	18,26	21,44	25,40	28,57	10
19,65		Refer to X.S.	30,00	37,55	41,77	48,50	61,00	
8,38	10,31	14,27	17,48	21,44	25,40	28,57	33,32	12
26,03	29,57	41,31	49,94	61,50	70,82	79,00	90,34	
Voir STD	11,13	15,09	19,05	23,83	27,79	31,75	35,71	14
	39,98	55,84	69,92	94,00	95,00	112,00	123,94	
Refer to STD	Voir E.F.	16,66	21,44	26,19	30,96	36,53	40,49	16
	Refer to X.S.	80,81	102,15	130,00	137,00	161,50	183,00	

(1) The dimension may be 11 mm at the manufacturer's option. Weights are approximate.



coudes long rayon à 45°

ASME B 16.9-1993

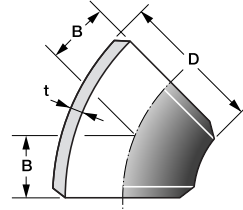

45° long radius elbows

ASME B 16.9-1993

Diamètre Nominal Nominal Pipe Size (NPS)	Dia. extérieur au chanfrein Outside diameter at bevel	Centre-à-extrémité Center-to-end	STD	E.F. X.S.	X.E.F. X.X.S.	SCH 10	SCH 20
Pouces/Inches	D – mm	B – mm	† ép./W.T. mm masse/weight kg				
18	457	286	9,52	12,70		6,35	7,92
			60,00	79,00		41,00	56,00
20	508	318	9,52	12,70		6,35	
			71,20	97,16		50,00	
22	559	343	9,52	12,70		6,35	
			89,00	118,00		60,00	
24	610	381	9,52	12,70		6,35	
			102,95	141,20		73,00	
26	660	406	9,52	12,70		7,92	
			124,90	165,71		104,00	
28	711	438	9,52	12,70		7,92	
			150,00	202,00		121,00	
30	762	470	9,52	12,70		7,92	
			167,00	220,00		139,00	
32	813	502	9,52	12,70		7,92	
			193,00	255,00		158,00	
34	864	533	9,52	12,70		7,92	
			215,00	280,00		178,00	
36	914	565	9,52	12,70		7,92	
			241,00	312,00		200,00	
38	965	600	9,52	12,70			
			272,00	354,00			
40	1016	632	9,52	12,70			
			290,00	372,00			
42	1067	660	9,52	12,70			
			327,00	420,00			
44	1118	695	9,52	12,70			
			363,00	488,00			
46	1168	727	9,52	12,70			
			408,00	530,00			
48	1219	759	9,52	12,70			
			443,00	567,00			

Les masses indiquées sont approximatives

SCH 30	SCH 40	SCH 60	SCH 80	SCH 100	SCH 120	SCH 140	SCH 160	Diamètre Nominal Nominal Pipe Size (NPS)
† ép./W.T. mm masse/weight kg								Pouces/Inches
11,13	14,27	19,05	23,83	29,36	34,93	39,67	45,24	18
69,91	88,53	115,77	143,92	195,00	202,50	211,00	272,00	
12,70	15,09	20,62	26,18	32,54	38,10	44,45	50,01	20
97,16	114,00	155,72	195,67	238,00	254,00	303,50	385,00	
12,70		22,22	28,58	34,92	41,27	47,62	53,97	22
128,10		205,35	256,70	329,00	365,00	425,00	510,00	
14,27	17,48	24,61	30,96	38,89	46,02	52,37	59,54	24
159,35	192,04	266,95	333,70	410,00	477,00	545,00	635,00	
								26
15,88								28
239,00								
15,88								30
275,00								
15,88	17,48							32
313,00	344,00							
15,88	17,48							34
354,00	389,00							
15,88	19,05							36
398,00	476,00							
								38
								40
								42
								44
								46
								48

Weights are approximate



coudes long rayon à 90°

ASME B 16.9-1993

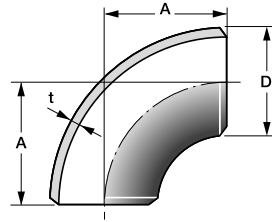

90° long radius elbows

ASME B 16.9-1993

Diamètre Nominal Nominal Pipe Size (NPS)	Dia. extérieur au chanfrein Outside diameter at bevel	Centre-à-extrémité Center-to-end	STD	E.F. X.S.	X.E.F. X.X.S.	SCH 10	SCH 20
Pouces/Inches	D – mm	A – mm	t ép./W.T. mm masse/weight kg				
1/2	21	38	2,77 0,08	3,73 0,18	7,47		
3/4	27	38 (1)	2,87 0,08	3,91 0,20	7,82		
1	33	38	3,38 0,15	4,55 0,20	9,09 0,40		
1 1/4	42	48	3,56 0,25	4,85 0,35	9,70 0,61		
1 1/2	48	57	3,68 0,36	5,08 0,60	10,16 0,90		
2	60	76	3,91 0,65	5,54 0,94	11,07 1,80		
2 1/2	73	95	5,16 1,28	7,01 1,70	14,02 3,21		
3	89	114	5,49 2,03	7,62 2,75	15,24 5,20		
3 1/2	102	133	5,74 2,87	8,08 3,95			
4	114	152	6,02 3,90	8,56 5,40	17,12 10,30		
5	141	190	6,55 6,50	9,52 8,85	19,05 18,11		
6	168	229	7,11 10,20	10,97 15,35	21,95 30,00		
8	219	305	8,18 20,30	12,70 29,90	22,23 54,50	6,35 16,57	
10	273	381	9,27 37,00	12,70 48,60	25,40 97,00	6,35 25,79	
12	324	457	9,52 54,00	12,70 70,00	25,40 140,00	6,35 37,23	
14	356	533	9,52 68,00	12,70 94,35		6,35 57,47	7,92 59,93
16	406	610	9,52 89,20	12,70 124,75		6,35 63,20	7,92 78,09

(1) La dimension peut être de 29 mm suivant option du fabricant. Les masses indiquées sont approximatives.

SCH 30	SCH 40	SCH 60	SCH 80	SCH 100	SCH 120	SCH 140	SCH 160	Diamètre Nominal Nominal Pipe Size (NPS)
t ép./W.T. mm masse/weight kg								Pouces/Inches
2,41							4,78	1/2
							0,22	
2,41							5,56	3/4
							0,25	
2,90							6,35	1
							0,30	
2,97							6,35	1 1/4
							0,44	
3,18							7,13	1 1/2
							0,80	
3,18	Voir STD		Voir E.F.				8,74	2
							1,50	
4,78							9,52	2 1/2
							2,35	
4,78	Refer to STD		Refer to X.S.				11,13	3
							4,00	
4,78								3 1/2
							11,13	4
							6,95	
							12,70	5
							12,62	
							14,27	6
							18,26	
							23,00	8
							27,00	
7,03		10,31		15,09	18,26	20,62	23,01	8
17,50		26,30		38,00	40,50	52,00	58,00	10
7,80		Voir E.F.	15,09	18,26	21,44	25,40	28,57	
31,30		Refer to X.S.	57,11	75,00	85,00	97,00	123,00	12
8,38	10,31	14,27	17,48	21,44	25,40	28,57	33,32	14
46,06	58,15	82,62	94,82	123,00	140,00	157,00	180,00	16
Voir STD	11,13	15,09	19,05	23,83	27,79	31,75	35,71	
Refer to STD	79,96	111,26	132,16	188,00	190,00	224,00	247,50	
Refer to STD	Voir E.F.	16,66	21,44	26,19	30,96	36,53	40,49	
	Refer to X.S.	161,17	204,30	260,00	274,00	323,00	367,00	

(1) The dimension may be 29 mm at the manufacturer's option. Weights are approximate



coudes long rayon à 90°

ASME B 16.9-1993

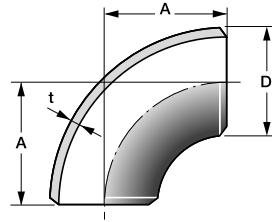

90° long radius elbows

ASME B 16.9-1993

Diamètre Nominal Nominal Pipe Size (NPS)	Dia. extérieur au chanfrein Outside diameter at bevel	Centre-à-extrémité Center-to-end	STD	E.F. X.S.	X.E.F. X.X.S.	SCH 10	SCH 20	
			† ép./W.T. mm masse/weight kg					
Pouces/Inches	D – mm	A – mm						
18	457	686	9,52	12,70		6,35	7,92	
			112,90	157,50		82,00	99,43	
20	508	762	9,52	12,70		6,35		
			142,40	194,30		100,00		
22	559	838	9,52	12,70		6,35		
			178,00	236,00		120,00		
24	610	914	9,52	12,70		6,35		
			202,00	268,50		146,00		
26	660	991	9,52	12,70		7,92		
			270,00	348,00		208,00		
28	711	1067	9,52	12,70		7,92		
			300,00	404,00		242,00		
30	762	1143	9,52	12,70		7,92		
			333,00	441,00		278,00		
32	813	1219	9,52	12,70		7,92		
			390,00	510,00		316,00		
34	864	1295	9,52	12,70		7,92		
			430,00	560,00		357,00		
36	914	1372	9,52	12,70		7,92		
			482,00	625,00		400,00		
38	965	1448	9,53	12,70				
			540,00	710,00				
40	1016	1524	9,52	12,70				
			580,00	745,00				
42	1067	1600	9,52	12,70				
			655,00	840,00				
44	1118	1676	9,53	12,70				
			726,00	970,00				
46	1168	1753	9,53	12,70				
			816,00	1055,00				
48	1219	1829	9,52	12,70				
			885,00	1134,00				

Les masses indiquées sont approximatives

SCH 30	SCH 40	SCH 60	SCH 80	SCH 100	SCH 120	SCH 140	SCH 160	Diamètre Nominal Nominal Pipe Size (NPS)
† ép./W.T. mm masse/weight kg								
								Pouces/Inches
11,13	14,27	19,05	23,83	29,36	34,93	39,67	45,24	18
139,83	177,06	231,54	287,84	390,00	405,00	422,00	545,00	
12,70	15,09	20,62	26,18	32,54	38,10	44,45	50,01	20
194,30	230,00	311,44	390,90	476,00	508,00	607,00	770,00	
12,70		22,22	28,58	34,92	41,27	47,62	53,97	22
250,20		412,70	523,40	638,00	700,00	850,00	1020,00	
14,27	17,48	24,61	30,96	38,89	46,02	52,37	59,54	24
318,70	384,00	533,90	667,40	820,00	954,00	1100,00	1270,00	
								26
15,88								
478,00								28
15,88								
550,00								30
15,88	17,48							
627,00	689,00							32
15,88	17,48							
708,00	778,00							34
15,88	19,05							
795,00	951,00							36
								38
								40
								42
								44
								46
								48

Weights are approximate



coudes long rayon à 180°

ASME B 16.9-1993

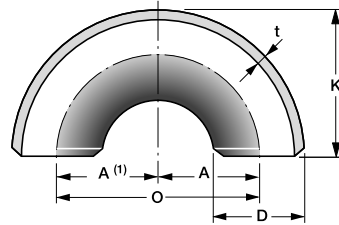

180° long radius returns

ASME B 16.9-1993

Diamètre Nominal Nominal Pipe Size (NPS)	Dia. extérieur au chanfrein Outside diameter at bevel	Entraxe Center-to-center	Hauteur Back-to-face	STD	E.F. X.S.	X.E.F. X.X.S.	SCH 10	SCH 20
				t ép./W.T. mm masse/weight kg				
Pouces/Inches	D – mm	O – mm	K – mm					
1/2	21	76	48	2,77 0,16	3,73 0,35	7,47		
3/4	27	76 (2)	51 (2)	2,87 0,16	3,91 0,35	7,82		
1	33	76	56	3,38 0,31	4,55 0,40	9,09 0,69		
1 1/4	42	95	70	3,56 0,50	4,85 0,70	9,70 1,22		
1 1/2	48	114	83	3,68 0,73	5,08 1,20	10,16 1,80		
2	60	152	106	3,91 1,30	5,54 1,88	11,07 3,40		
2 1/2	73	191	132	5,16 2,57	7,01 3,40	14,02 6,40		
3	89	229	159	5,49 4,07	7,62 5,50	15,24 10,35		
3 1/2	102	267	184	5,74 5,74	8,08 7,90			
4	114	305	210	6,02 7,80	8,56 10,80	17,12 20,60		
5	141	381	262	6,55 13,00	9,52 17,70	19,05 36,23		
6	168	457	313	7,11 20,40	10,97 30,70	21,95 59,50		
8	219	610	414	8,18 40,60	12,70 59,80	22,23 109,00	6,35 33,14	
10	273	762	518	9,27 74,00	12,70 97,20	25,40 194,00	6,35 51,58	
12	324	914	619	9,52 108,00	12,70 140,00	25,40 280,00	6,35 74,46	
14	356	1067	711	9,52 136,00	12,70 188,70		6,35 114,94	7,92 119,86

(1) A est égal à la moitié de O.
 (2) Les dimensions O et K pour NPS 3/4" peuvent être respectivement 57 et 43 mm à l'option du fabricant.
 Les masses indiquées sont approximatives

SCH 30	SCH 40	SCH 60	SCH 80	SCH 100	SCH 120	SCH 140	SCH 160	Diamètre Nominal Nominal Pipe Size (NPS)
t ép./W.T. mm masse/weight kg								Pouces/Inches
2,41							4,78	1/2
							0,43	
2,41							5,56	3/4
							0,43	
2,90							6,35	1
							0,53	
2,97							6,35	1 1/4
							0,88	
3,18							7,13	1 1/2
							1,36	
3,18	Voir STD		Voir E.F.				8,74	2
							3,00	
4,78							9,52	2 1/2
							4,67	
4,78	Refer to STD		Refer to X.S.				11,13	3
							8,03	
4,78								3 1/2
4,78							11,13	4
							13,90	
							12,70	5
							25,24	
							30,87	6
							14,27	
							18,26	
							39,26	8
							54,00	
7,03		10,31		15,09	18,26	20,62	23,01	
34,98		53,12		76,00	81,00	104,00	110,00	10
7,80		Voir E.F.	15,09	18,26	21,44	25,40	28,57	
62,62		Refer to X.S.	119,86	150,00	190,00	194,00	218,00	12
8,38	10,31	14,27	17,48	21,44	25,40	28,57	33,32	
92,12	116,30	165,25	198,85	246,00	280,00	314,00	360,00	14
Voir STD	11,13	15,09	19,05	23,83	27,79	31,75	35,71	
Refer to STD	159,93	222,46	270,00	376,00	380,00	448,00	495,00	

(1) Dimension «A» is equal to 1/2 of dimension «O».
 (2) O and K dimensions for size NPS 3/4" may be O = 57 mm and K = 43 mm at the manufacturer's option.
 Weights are approximate



coudes long rayon à 180°

ASME B 16.9-1993

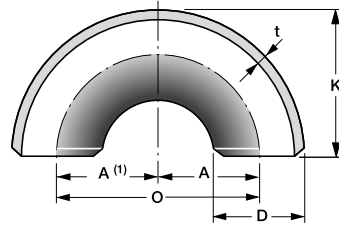

180° long radius returns

ASME B 16.9-1993

Diamètre Nominal Nominal Pipe Size (NPS)	Dia. extérieur au chanfrein Outside diameter at bevel	Entraxe Center-to-center	Hauteur Back-to-face	STD	E.F. X.S.	X.E.F. X.X.S.	SCH 10	SCH 20
				t ép./W.T. mm masse/weight kg				Voir STD Refer to STD
Pouces/Inches	D – mm	O – mm	K – mm					
16	406	1219	813	9,52	12,70		6,35	7,92
				178,40	249,50		165,24	156,18
18	457	1372	914	9,52	12,70		6,35	7,92
				225,80	315,08		164,00	198,86
20	508	1524	1016	9,52	12,70		6,35	
				284,80	388,62		200,00	
22	559	1676	1118	9,52	12,70		6,35	
				346,00	466,00		240,00	
24	610	1829	1219	9,52	12,70		6,35	
				411,80	564,78		292,00	

(1) A est égal à la moitié de O.
Les masses indiquées sont approximatives

SCH 30	SCH 40	SCH 60	SCH 80	SCH 100	SCH 120	SCH 140	SCH 160	Diamètre Nominal Nominal Pipe Size (NPS)
t ép./W.T. mm masse/weight kg							Pouces/Inches	
Voir STD Refer to STD	Voir E.F. Refer to X.S.	16,66	21,44	26,19	30,96	36,53	40,49	16
		322,34	404,00	520,00	548,00	646,00	734,00	
11,13	14,27	19,05	23,83	29,36	34,93	39,67	45,24	18
279,66	354,12	463,08	581,00	780,00	810,00	844,00	1090,00	
12,70	15,09	20,62	26,18	32,54	38,10	44,45	50,01	20
388,62	460,00	622,89	781,00	952,00	1016,00	1214,00	1540,00	
12,70		22,22	28,58	34,92	41,27	47,62	53,97	22
510,40		825,40	1046,00	1316,00	1400,00	1700,00	2040,00	
14,27	17,48	24,61	30,96	38,89	46,02	52,37	59,54	24
637,42	768,17	1067,80	1335,00	1640,00	1908,00	2170,00	2540,00	

(1) Dimension «A» is equal to 1/2 of dimension «O».
Weights are approximate



coudes court rayon à 90°

ASME B 16.28-1994

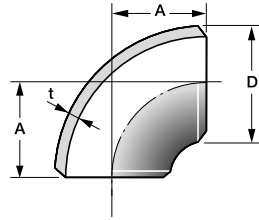

90° short radius elbows

ASME B 16.28-1994

Diamètre Nominal Nominal Pipe Size (NPS)	Dià. extérieur au chanfrein Outside diameter at bevel	Centre-à-extrémité Center-to-end	STD	E.F. X.S.	X.E.F. X.X.S.	SCH 10	SCH 20
Pouces/Inches	D – mm	A – mm	† ép./W.T. mm masse/weight kg				
1	33	25	3,38	4,55	9,09		
			0,10	0,13	0,23		
1 1/4	42	32	3,56	4,85	9,70		
			0,16	0,23	0,41		
1 1/2	48	38	3,68	5,08	10,16		
			0,24	0,30	0,60		
2	60	51	3,91	5,54	11,07		
			0,43	0,60	1,13		
2 1/2	73	64	5,16	7,01	14,02		
			0,82	1,15	2,03		
3	89	76	5,49	7,62	15,24		
			1,35	1,85	3,47		
3 1/2	102	89	5,74	8,08			
			1,90	2,60			
4	114	102	6,02	8,56	17,12		
			2,60	3,55	6,86		
5	141	127	6,55	9,52	19,05		
			4,35	6,20	12,02		
6	168	152	7,11	10,97	21,95		
			6,45	10,20	19,90		
8	219	203	8,18	12,70	22,23		6,35
			16,50	22,50	36,12		11,10
10	273	254	9,27	12,70	25,40		6,35
			31,15	31,15	64,94		17,35
12	324	305	9,52	12,70	25,40		6,35
			45,00	49,03	93,91		25,00
14	356	356	9,52	12,70		6,35	7,92
			52,50	63,11		30,50	39,50
16	406	406	9,52	12,70		6,35	7,92
			71,25	82,63		39,00	52,20
18	457	457	9,52	12,70		6,35	7,92
			90,00	104,87		48,50	65,35
20	508	508	9,52	12,70		6,35	
			110,00	129,54		67,50	
22	559	559	9,52	12,70		6,35	
			132,00	157,00		84,50	
24	610	610	9,52	12,70		6,35	
			165,00	188,41		96,50	

Les masses indiquées sont approximatives.

SCH 30	SCH 40	SCH 60	SCH 80	SCH 100	SCH 120	SCH 140	SCH 160	Diamètre Nominal Nominal Pipe Size (NPS)
† ép./W.T. mm masse/weight kg								Pouces/Inches
2,90							6,35	1
							0,18	
2,97							6,35	1 1/4
							0,29	
3,18							7,13	1 1/2
							0,45	
3,18							8,74	2
							0,93	
4,78							9,52	2 1/2
							1,56	
4,78	Voir STD		Voir E.F.				11,13	3
							2,68	
4,78								3 1/2
4,78	Refer to STD		Refer to X.S.			11,13	13,50	4
						4,72	5,62	
						12,70	15,87	5
						8,44	10,28	
						14,27	18,26	6
						13,62	16,97	
7,03		10,31		15,09	18,26	20,62	23,01	8
12,26		17,75		26,40	30,00	32,00	37,00	
7,80		Voir E.F.	15,09	18,26	21,44	25,40	28,57	10
21,25		Refer to X.S.	40,00	50,00	59,00	62,00	72,00	
8,38	10,31	14,22	17,48	21,44	25,40	28,57	33,32	12
32,78	40,00	54,93	66,28	81,00	92,00	99,00	120,00	
Voir STD	11,12	15,09	19,05	23,83	27,79	31,75	35,71	14
	55,39	74,00	93,07	120,00	124,00	139,00	165,00	
Refer to STD	Voir E.F.	16,66	21,44	26,19	30,96	36,53	40,49	16
	Refer to X.S.	107,14	136,20	166,00	171,50	198,00	245,00	
11,13	14,27	19,05	23,83	29,36	34,92	39,67	45,24	18
93,07	117,59	154,36	191,60	257,00	283,00	387,00	346,00	
12,70	15,09	20,62	26,18	32,54	38,10	44,45	50,01	20
129,84	153,45	207,48	260,14	332,00	376,00	430,00	478,00	
12,70		22,22	28,58	34,92	41,27	47,62	53,97	22
171,50		281,50	350,50	430,00	497,00	555,00	627,00	
14,27	17,48	24,61	30,96	38,89	46,02	52,37	59,54	24
213,38	256,00	355,48	443,55	530,00	621,00	680,00	835,00	

Weights are approximate.



coudes court rayon à 180°

ASME B 16.28-1994

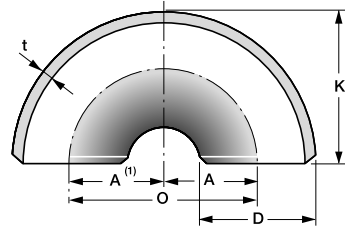

180° short radius returns

ASME B 16.28-1994

Diamètre Nominal Nominal Pipe Size (NPS)	Dia. extérieur au chanfrein Outside diameter at bevel	Entraxe Center-to-center	Hauteur Back-to-face	STD	E.F. X.S.	X.E.F. X.X.S.	SCH 10	SCH 20
				t ép./W.T. mm masse/weight kg				
Pouces/Inches	D – mm	O – mm	K – mm					
1	33	51	41	3,38	4,55	9,09		
1 1/4	42	64	52	0,20	0,27	0,46		
1 1/2	48	76	62	3,56	4,85	9,70		
2	60	102	81	0,33	0,50	0,82		
2 1/2	73	127	100	3,68	5,08	10,16		
3	89	152	121	0,48	0,60	1,20		
3 1/2	102	178	140	3,91	5,54	11,07		
4	114	203	159	0,86	1,20	2,26		
5	141	254	197	5,16	7,01	14,02		
6	168	305	237	1,64	2,30	4,06		
8	219	406	313	5,49	7,62	15,24		6,35
10	273	508	391	2,70	3,70	6,94		22,25
12	324	610	467	5,74	8,08			6,35
14	356	711	533	3,80	5,20		6,35	7,92
16	406	813	610	6,02	8,56	17,12		79,00
18	457	914	686	5,20	7,10	13,72		6,35
20	508	1016	762	6,55	9,52	19,05		7,92
22	559	1118	838	8,70	12,40	24,00		6,35
24	610	1219	914	7,11	10,97	21,95		130,00
				8,18	12,70	22,23		6,35
				33,00	45,00	72,00		22,25
				9,27	12,70	25,40		6,35
				62,30	62,30	130,00		34,70
				9,52	12,70	25,40		6,35
				90,00	98,06	188,00		50,00
				9,52	12,70		6,35	7,92
				106,00	126,21		60,00	79,00
				9,52	12,70		6,35	7,92
				142,50	165,26		79,35	104,45
				9,52	12,70		6,35	7,92
				180,00	209,75		97,50	130,75
				9,52	12,70		6,35	
				219,00	259,70		130,00	
				9,52	12,70		6,35	
				264,00	314,00		160,00	
				9,52	12,70		6,35	
				330,00	376,82		192,00	

(1) A est égal à la moitié de O.
Les masses indiquées sont approximatives.

SCH 30	SCH 40	SCH 60	SCH 80	SCH 100	SCH 120	SCH 140	SCH 160	Diamètre Nominal Nominal Pipe Size (NPS)
t ép./W.T. mm masse/weight kg								
Pouces/Inches								
2,90							6,35	1
							0,36	
2,97							6,35	1 1/4
							0,58	
3,18							7,13	1 1/2
							0,90	
3,18							8,74	2
							1,86	
4,78							9,52	2 1/2
							3,12	
4,78	Voir STD		Voir E.F.				11,13	3
							5,36	
4,78								3 1/2
4,78	Refer to STD		Refer to X.S.			11,13	13,50	4
						9,45	11,24	
						12,70	15,87	
						18,00	20,56	5
						14,27	18,26	
						27,00	33,94	6
7,03		10,31		15,09	18,26	20,62	23,01	
24,51		35,10		52,65	58,00	64,00	75,00	8
7,80		Voir E.F.	15,09	18,26	21,44	25,40	28,57	
42,38		Refer to X.S.	81,00	100,00	106,00	124,00	144,00	10
8,38	10,31	14,27	17,48	21,44	25,40	28,57	33,32	
65,83	79,20	108,90	136,00	162,00	184,00	198,00	240,00	12
Voir STD	11,12	15,09	19,05	23,83	27,79	31,75	35,71	
Refer to STD	109,80	146,70	187,00	240,00	248,00	276,00	330,00	14
	Voir E.F.	16,66	21,44	26,19	30,96	36,53	40,49	
	Refer to X.S.	212,40	276,00	332,00	343,00	396,00	490,00	16
11,13	14,27	19,05	23,83	29,36	34,92	39,67	45,24	
186,14	233,10	306,00	386,00	515,00	566,00	774,00	693,00	18
12,70	15,09	20,62	26,18	32,54	38,10	44,45	50,01	
259,68	304,20	411,30	522,00	664,00	752,00	860,00	957,00	20
12,70		22,22	28,58	34,92	41,27	47,62	53,97	
348,00		563,00	676,00	840,00	984,00	1110,00	12,55	22
14,27	17,48	24,61	30,96	38,89	46,02	52,37	59,54	
426,76	507,60	704,70	887,00	1060,00	1242,00	1360,00	1669,00	24

(1) Dimension «A» is equal to 1/2 of dimension «O».
Weights are approximate.



tés égaux

ASME B 16.9-1993

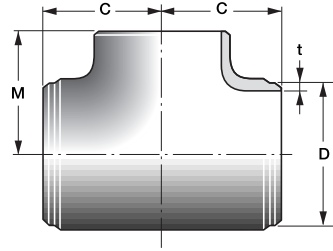

straight tees

ASME B 16.9-1993

Diamètre Nominal Nominal Pipe Size (NPS)	Dia. extérieur au chanfrein Outside diameter at bevel	Encombrement Center-to-end		STD	E.F. X.S.	X.E.F. X.X.S.	SCH 10	SCH 20
		C – mm	M – mm	† ép./W.T. mm masse/weight kg				
Pouces/Inches	D – mm	C – mm	M – mm					
1/2	21	25	25	2,77 0,16	3,73 0,25	7,47		
3/4	27	29	29	2,87 0,20	3,91 0,27	7,82 0,38		
1	33	38	38	3,38 0,29	4,55 0,35	9,09 0,58		
1 1/4	42	48	48	3,56 0,53	4,85 0,65	9,70 1,05		
1 1/2	48	57	57	3,68 0,77	5,08 0,96	10,16 1,56		
2	60	64	64	3,91 1,88	5,54 1,90	11,07 2,69		
2 1/2	73	76	76	5,16 2,69	7,01 3,07	14,02 4,54		
3	89	86	86	5,49 3,82	7,62 4,50	15,24 7,63		
3 1/2	102	95	95	5,74 5,18	8,08 6,17			
4	114	105	105	6,02 6,00	8,56 8,44	17,12 17,00		
5	141	124	124	6,55 9,94	9,52 12,94	19,05 25,00		
6	168	143	143	7,11 16,48	10,97 19,30	21,95 39,00		
8	219	178	178	8,18 33,00	12,70 34,50	22,23 69,00	6,35 29,00	
10	273	216	216	9,27 49,35	12,70 58,57	25,40 98,00	6,35 34,70	
12	324	254	254	9,52 65,00	12,70 84,90	25,40 150,00	6,35 59,00	
14	356	279	279	9,52 93,00	12,70 127,12		6,35 87,16	7,92 90,00
16	406	305	305	9,52 115,00	12,70 167,52		6,35 90,80	7,92 100,00

Les masses indiquées sont approximatives.

SCH 30	SCH 40	SCH 60	SCH 80	SCH 100	SCH 120	SCH 140	SCH 160	Diamètre Nominal Nominal Pipe Size (NPS)
† ép./W.T. mm masse/weight kg								
								Pouces/Inches
2,41							4,78	1/2
							0,28	
2,41							5,56	3/4
							0,29	
2,90							6,35	1
							0,45	
2,97							6,35	1 1/4
							0,77	
3,18							7,13	1 1/2
							1,21	
3,18	Voir STD		Voir E.F.				8,74	2
							2,25	
4,78							9,52	2 1/2
							3,42	
4,78	Refer to STD		Refer to X.S.				11,13	3
							6,21	
4,78								3 1/2
4,78							11,13	4
							9,00	
							12,70	5
							18,00	
							18,00	5
							23,93	
							14,27	6
							18,26	
							24,00	6
							38,59	
7,03		10,31		15,09	18,26	20,62	23,01	8
31,00		34,50		43,65	50,00	54,00	71,00	
7,80		12,70	15,09	18,26	21,44	25,40	28,57	10
36,77		58,57	68,00	74,00	93,00	99,00	120,00	
8,38	10,31	14,27	17,48	21,44	25,40	28,57	33,32	12
61,74	70,50	102,60	115,00	136,00	150,00	177,00	184,00	
Voir STD	11,13	15,09	19,05	23,83	27,79	31,75	35,71	14
Voir STD	114,41	141,20	165,00	206,00	240,00	275,00	300,00	
Refer to STD	Voir E.F.	16,66	21,44	26,19	30,96	36,53	40,49	16
Refer to STD	Refer to X.S.	207,93	249,00	305,00	330,00	385,00	425,00	

Weights are approximate.



tés égaux

ASME B 16.9-1993

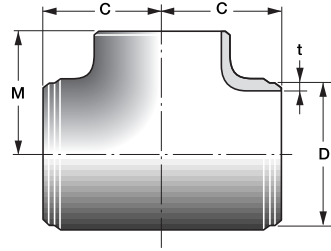

straight tees

ASME B 16.9-1993

Diamètre Nominal Nominal Pipe Size (NPS)	Dia. extérieur au chanfrein Outside diameter at bevel	Encombrement Center-to-end		STD	E.F. X.S.	X.E.F. X.X.S.	SCH 10	SCH 20
		C – mm	M* – mm	† ép./W.T. mm masse/weight kg				
18	457	343	343	9,52	12,70		6,35	7,92
				135,00	190,00		94,50	127,12
20	508	381	381	9,52	12,70		6,35	
				168,00	245,00		120,00	
22	559	419	419	9,52	12,70		6,35	
				200,00	280,00		143,00	
24	610	432	432	9,52	12,70		6,35	
				240,00	350,00		170,00	
26	660	495	495	9,52	12,70		7,92	
				288,00	360,50		240,00	
28	711	521	521	9,52	12,70		7,92	
				337,00	421,00		280,00	
30	762	559	559	9,52	12,70		7,92	
				388,50	483,50		322,00	
32	813	597	597	9,52	12,70		7,92	
				451,00	559,00		375,00	
34	864	635	635	9,52	12,70		7,92	
				516,00	645,00		429,00	
36	914	673	673	9,52	12,70		7,92	
				587,50	731,00		488,00	
38	965	711	711	9,52	12,70			
				638,00	812,00			
40	1016	749	749	9,52	12,70			
				690,00	894,50			
42	1067	762	711	9,52	12,70			
				831,00	1045,00			
44	1118	813	762	9,52	12,70			
				899,00	1194,00			
46	1168	851	795	9,52	12,70			
				1007,00	1346,00			
48	1219	889	838	9,52	12,70			
				1112,50	1498,50			

* L'encombrement M pour NPS ≥ 26" est recommandé mais non imposé
Les masses indiquées sont approximatives.

SCH 30	SCH 40	SCH 60	SCH 80	SCH 100	SCH 120	SCH 140	SCH 160	Diamètre Nominal Nominal Pipe Size (NPS)
† ép./W.T. mm masse/weight kg							Pouces/Inches	
11,13	14,27	19,05	23,83	29,36	34,93	39,67	45,24	18
181,14	238,35	277,85	322,00	380,00	450,00	500,00	590,00	20
12,70	15,09	20,62	26,18	32,54	38,10	44,45	50,01	22
265,00	320,52	378,64	459,05	540,00	590,00	720,00	790,00	24
12,70		22,22	28,58	34,92	41,27	47,62	53,97	26
355,00		510,00	600,00	725,00	840,00	950,00	1100,00	28
14,27	17,48	24,61	30,96	38,89	46,02	52,37	59,54	30
443,55	570,68	656,48	748,00	910,00	1100,00	1180,00	1310,00	32
								34
								36
								38
								40
								42
								44
								46
								48

* Outlet dimension M for NPS ≥ 26" is recommended but not required
Weights are approximate.



tés réduits

ASME B 16.9-1993

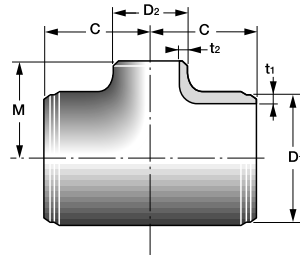

Diamètre Nominal Nominal Pipe Size (NPS)	Dia. extérieur au chanfrein Outside diameter at bevel	Encombrement Center-to-end		STD	E.F. X.S.	X.E.F. X.X.S.	SCH 10	SCH 20
		C – mm	M – mm	t ₁ ép./W.T. mm	t ₂ ép./W.T. mm	masse/weight kg		
Pouces/Inches	D – mm	C – mm	M – mm					
1/2 x 3/8	21	25	25	2,77	3,73			
	17			2,31	3,20			
				0,16	0,25			
1/2 x 1/4	21	25	25	2,77	3,73			
	14			2,24	3,03			
				0,16	0,25			
3/4 x 1/2	27	29	29	2,87	3,91	7,82		
	21			2,77	3,73	7,47		
				0,25	0,34	0,40		
3/4 x 3/8	27	29	29	2,87	3,91			
	17			2,31	3,20			
				0,25	0,34			
1 x 3/4	33	38	38	3,38	4,55	9,09		
	27			2,87	3,91	7,82		
				0,35	0,40	0,57		
1 x 1/2	33	38	38	3,38	4,55	9,09		
	21			2,77	3,73	7,47		
				0,34	0,40	0,55		
1 1/4 x 1	42	48	48	3,56	4,85	9,70		
	33			3,38	4,55	9,09		
				0,60	0,60	1,09		
1 1/4 x 3/4	42	48	48	3,56	4,85	9,70		
	27			2,87	3,91	7,82		
				0,60	0,59	1,02		
1 1/4 x 1/2	42	48	48	3,56	4,85	9,70		
	21			2,77	3,73	7,47		
				0,60	0,58	1,00		
1 1/2 x 1 1/4	48	57	57	3,68	5,08	10,16		
	42			3,56	4,85	9,70		
				0,80	0,99	1,62		
1 1/2 x 1	48	57	57	3,68	5,08	10,16		
	33			3,38	4,55	9,09		
				0,73	0,96	1,55		

Les masses indiquées sont approximatives.



reducing outlet tees

ASME B 16.9-1993

SCH 30	SCH 40	SCH 60	SCH 80	SCH 100	SCH 120	SCH 140	SCH 160	Diamètre Nominal Nominal Pipe Size (NPS)
t ₁ ép./W.T. mm								Pouces/Inches
t ₂ ép./W.T. mm								
masse/weight kg								
2,41								1/2 x 3/8
1,85								
2,41								
2,41								1/2 x 1/4
1,85								
2,41							5,56	
2,41							4,78	3/4 x 1/2
							0,27	
2,41								
1,85								3/4 x 3/8
2,90							6,35	
2,41							5,56	
	Voir STD		Voir E.F.				0,46	1 x 3/4
2,90							6,35	
2,41							4,78	
							0,44	1 x 1/2
2,97	Refer to STD		Refer to X.S.				6,35	
2,90							6,35	
							0,80	1 1/4 x 1
2,97							6,35	
2,41							5,56	
							0,78	1 1/4 x 3/4
2,97							6,35	
2,41							4,78	
							0,76	1 1/4 x 1/2
3,18							7,13	
2,97							6,35	
							1,25	1 1/2 x 1 1/4
3,18							7,13	
2,90							6,35	
							1,25	1 1/2 x 1

Weights are approximate.



tés réduits

ASME B 16.9-1993

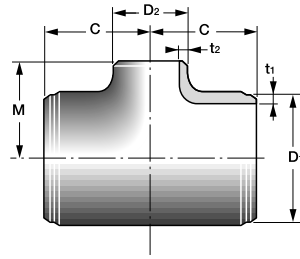

reducing outlet tees

ASME B 16.9-1993

Diamètre Nominal Nominal Pipe Size (NPS)	Dia. extérieur au chanfrein Outside diameter at bevel	Encombrement Center-to-end		STD	E.F. X.S.	X.E.F. X.X.S.	SCH 10	SCH 20
		C - mm	M - mm	t ₁ ép./W.T. mm				
Pouces/Inches	D - mm	C - mm	M - mm	t ₂ ép./W.T. mm				
				masse/weight kg				
1 1/2 x 3/4	48	57	57	3,68	5,08	10,16		
	27			2,87	3,91	7,82		
				0,73	0,94	1,50		
1 1/2 x 1/2	48	57	57	3,68	5,08	10,16		
	21			2,77	3,73	7,47		
				1,35	1,50	2,54		
2 x 1 1/2	60	64	60	3,91	5,54	11,07		
	48			3,68	5,08	10,16		
				1,50	2,05	2,73		
2 x 1 1/4	60	64	57	3,91	5,54	11,07		
	42			3,56	4,85	9,70		
				1,46	2,05	2,71		
2 x 1	60	64	51	3,91	5,54	11,07		
	33			3,38	4,55	9,09		
				1,31	2,05	2,65		
2 x 3/4	60	64	44	3,91	5,54	11,07		
	27			2,87	3,91	7,82		
				1,29	2,05	2,52		
2 1/2 x 2	73	76	70	5,16	7,01	14,02		
	60			3,91	5,54	11,07		
				2,08	3,37	4,58		
2 1/2 x 1 1/2	73	76	67	5,16	7,01	14,02		
	48			3,68	5,08	10,16		
				2,04	3,37	4,49		
2 1/2 x 1 1/4	73	76	64	5,16	7,01	14,02		
	42			3,56	4,85	9,70		
				1,99	3,37	4,46		
2 1/2 x 1	73	76	57	5,16	7,01	14,02		
	33			3,38	4,55	9,09		
				1,96	3,37	4,27		

Les masses indiquées sont approximatives.

SCH 30	SCH 40	SCH 60	SCH 80	SCH 100	SCH 120	SCH 140	SCH 160	Diamètre Nominal Nominal Pipe Size (NPS)
t ₁ ép./W.T. mm								Pouces/Inches
t ₂ ép./W.T. mm								
masse/weight kg								
3,18							7,13	1 1/2 x 3/4
2,41							5,56	
							1,19	
3,18							7,13	1 1/2 x 1/2
2,41							4,78	
							1,25	
3,18							8,74	2 x 1 1/2
3,18							7,13	
							2,27	
3,18							8,74	2 x 1 1/4
2,97							6,35	
							2,23	
3,18	Voir STD		Voir E.F.				8,74	2 x 1
2,90							6,35	
							2,19	
3,18	Refer to STD		Refer to X.S.				8,74	2 x 3/4
2,41							5,56	
							2,16	
4,78							9,52	2 1/2 x 2
3,18							8,74	
							3,45	
4,78							9,52	2 1/2 x 1 1/2
3,18							7,13	
							3,35	
4,78							9,52	2 1/2 x 1 1/4
2,97							6,35	
							3,30	
4,78							9,52	2 1/2 x 1
2,90							6,35	
							3,27	

Weights are approximate.



tés réduits

ASME B 16.9-1993

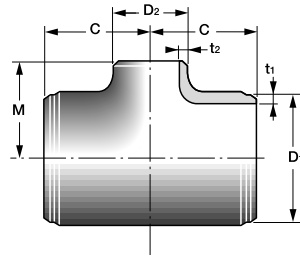

reducing outlet tees

ASME B 16.9-1993

Diamètre Nominal Nominal Pipe Size (NPS)	Dia. extérieur au chanfrein Outside diameter at bevel	Encombrement Center-to-end		STD	E.F. X.S.	X.E.F. X.X.S.	SCH 10	SCH 20
		C - mm	M - mm	t ₁ ép./W.T. mm				
Pouces/Inches	D - mm	C - mm	M - mm	t ₂ ép./W.T. mm				
				masse/weight kg				
3 x 2 1/2	89	86	83	5,49	7,62	15,24		
	73			5,16	7,01	14,02		
				3,00	4,25	7,70		
3 x 2	89	86	76	5,49	7,62	15,24		
	60			3,91	5,54	11,07		
				2,90	4,25	7,50		
3 x 1 1/2	89	86	73	5,49	7,62	15,24		
	48			3,68	5,08	10,16		
				2,88	4,25	7,50		
3 x 1 1/4	89	86	70	5,49	7,62	15,24		
	42			3,56	4,85	9,70		
				2,88	4,25	7,40		
3 1/2 x 3	102	95	92	5,74	8,08			
	89			5,49	7,62			
				4,09	6,52			
3 1/2 x 2 1/2	102	95	89	5,74	8,08			
	73			5,16	7,01			
				3,99	6,52			
3 1/2 x 2	102	95	83	5,74	8,08			
	60			3,91	5,54			
				3,85	6,52			
3 1/2 x 1 1/2	102	95	79	5,74	8,08			
	48			3,68	5,08			
				3,85	6,52			
4 x 3 1/2	114	105	102	6,02	8,56			
	102			5,74	8,08			
				5,27	7,50			
4 x 3	114	105	98	6,02	8,56	17,12		
	89			5,49	7,62	15,24		13,50
				5,18	7,50	17,00		11,13
								15,90

Les masses indiquées sont approximatives.

SCH 30	SCH 40	SCH 60	SCH 80	SCH 100	SCH 120	SCH 140	SCH 160	Diamètre Nominal Nominal Pipe Size (NPS)
t ₁ ép./W.T. mm								Pouces/Inches
t ₂ ép./W.T. mm								
masse/weight kg								
							11,13	3 x 2 1/2
							9,52	
							5,60	
							11,13	3 x 2
							8,74	
							5,50	
							11,13	3 x 1 1/2
							7,13	
							5,50	
							11,13	3 x 1 1/4
							6,35	
							5,40	
	Voir STD		Voir E.F.					3 1/2 x 3
	Refer to STD		Refer to X.S.					3 1/2 x 2 1/2
								3 1/2 x 2
								3 1/2 x 1 1/2
								4 x 3 1/2
							13,50	4 x 3
							11,13	
							15,90	

Weights are approximate.



tés réduits

ASME B 16.9-1993

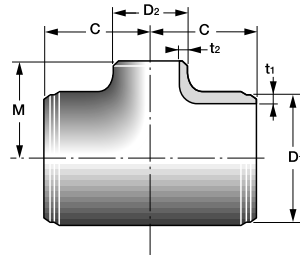

reducing outlet tees

ASME B 16.9-1993

Diamètre Nominal Nominal Pipe Size (NPS)	Dia. extérieur au chanfrein Outside diameter at bevel	Encombrement Center-to-end		STD	E.F. X.S.	X.E.F. X.X.S.	SCH 10	SCH 20
		D - mm	C - mm	M - mm	t ₁ ép./W.T. mm	t ₂ ép./W.T. mm	masse/weight kg	
4 x 2 1/2	114	105	95	6,02	8,56	17,12		
	73			5,16	7,01	14,02		
				5,13	7,50	17,00		
4 x 2	114	105	89	6,02	8,56	17,12		
	60			3,91	5,54	11,07		
				4,99	7,50	17,00		
4 x 1 1/2	114	105	86	6,02	8,56	17,12		
	48			3,68	5,08	10,16		
				4,95	7,50	17,00		
5 x 4	141	124	117	6,55	9,52	19,05		
	114			6,02	8,56	17,12		
				8,22	12,10	26,20		
5 x 3 1/2	141	124	114	6,55	9,52			
	102			5,74	8,08			
				8,08	12,10			
5 x 3	141	124	111	6,55	9,52	19,05		
	89			5,49	7,62	15,24		
				7,99	12,10	26,20		
5 x 2 1/2	141	124	108	6,55	9,52	19,05		
	73			5,16	7,01	14,02		
				7,90	12,10	22,20		
5 x 2	141	124	105	6,55	9,52	19,05		
	60			3,91	5,54	11,07		
				7,81	12,10	22,20		
6 x 5	168	143	137	7,11	10,97	21,95		
	141			6,55	9,52	19,05		
				16,00	18,00	38,00		
6 x 4	168	143	130	7,11	10,97	21,95		
	114			6,02	8,56	17,12		
				16,00	18,00	29,00		

Les masses indiquées sont approximatives.

SCH 30	SCH 40	SCH 60	SCH 80	SCH 100	SCH 120	SCH 140	SCH 160	Diamètre Nominal Nominal Pipe Size (NPS)
t ₁ ép./W.T. mm								Pouces/Inches
t ₂ ép./W.T. mm								
masse/weight kg								
							13,50	4 x 2 1/2
							9,52	
							15,50	
							13,50	4 x 2
							8,74	
							15,50	
							13,50	4 x 1 1/2
							7,13	
							15,50	
					12,70		15,87	5 x 4
					11,13		13,50	
					18,10		23,00	
	Voir STD		Voir E.F.					5 x 3 1/2
	Refer to STD		Refer to X.S.				15,87	5 x 3
							11,13	
							23,00	
							15,87	5 x 2 1/2
							9,52	
							23,00	
							15,87	5 x 2
							8,74	
							23,00	
					14,27		18,26	6 x 5
					12,70		15,87	
					29,00		30,00	
					14,27		18,26	6 x 4
					11,13		13,50	
					29,00		30,00	

Weights are approximate.



tés réduits

ASME B 16.9-1993

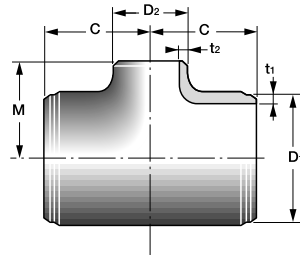

reducing outlet tees

ASME B 16.9-1993

Diamètre Nominal Nominal Pipe Size (NPS)	Dia. extérieur au chanfrein Outside diameter at bevel	Encombrement Center-to-end		STD	E.F. X.S.	X.E.F. X.X.S.	SCH 10	SCH 20
		D – mm	C – mm	M* – mm	t ₁ ép./W.T. mm	t ₂ ép./W.T. mm	masse/weight kg	
12 x 10	324	254	241	9,52	12,70	25,40		6,35
	273			9,27	12,70	25,40	6,35	
				63,00	85,00	150,00	43,00	
12 x 8	324	254	229	9,52	12,70	25,40		6,35
	219			8,18	12,70	22,23	6,35	
				63,00	82,00	129,00	41,00	
12 x 6	324	254	219	9,52	12,70	25,40		
	168			7,11	10,97	21,95		
				63,00	82,00	120,00		
12 x 5	324	254	216	9,52	12,70	25,40		
	141			6,55	9,52	19,05		
				63,00	82,00	120,00		
14 x 12	356	279	270	9,52	12,70			7,92
	324			9,52	12,70		6,35	
				111,00	127,00		95,00	
14 x 10	356	279	257	9,52	12,70			7,92
	273			9,27	12,70		6,35	
				107,00	127,00		90,00	
14 x 8	356	279	248	9,52	12,70			7,92
	219			8,18	12,70		6,35	
				107,00	122,00		90,00	
14 x 6	356	279	238	9,52	12,70			
	168			7,11	10,97			
				107,00	122,00			
16 x 14	406	305	305	9,52	12,70		6,35	7,92
	356			9,52	12,70		6,35	7,92
				119,00	167,00		84,00	100,00
16 x 12	406	305	295	9,52	12,70			7,92
	324			9,52	12,70		6,35	
				119,00	167,00		100,00	

* L'encombrement M pour NPS ≥ 14" est recommandé mais non imposé
Les masses indiquées sont approximatives.

SCH 30	SCH 40	SCH 60	SCH 80	SCH 100	SCH 120	SCH 140	SCH 160	Diamètre Nominal Nominal Pipe Size (NPS)
t ₁ ép./W.T. mm							Pouces/Inches	
t ₂ ép./W.T. mm								
masse/weight kg								
8,38	10,31	14,27	17,48	21,44	25,40	28,57	33,32	12 x 10
7,80	9,27	12,70	15,09	18,26	21,44	25,40	28,57	
62,00	67,00	103,00	103,00	126,00	149,00	160,00	171,00	
8,38	10,31	14,27	17,48	21,44	25,40	28,57	33,32	12 x 8
7,03	8,18	10,31	12,70	15,09	18,26	20,62	23,01	
60,00	64,00	82,00	82,00	122,00	133,00	144,00	155,00	
	10,31		17,48		25,40		33,32	12 x 6
	7,11		10,97		14,27		18,26	
	64,00		82,00		111,00		144,00	
	10,31		17,48		25,40		33,32	12 x 5
	6,55		9,52		12,70		15,87	
	64,00		82,00		103,00		144,00	
9,52	11,12	15,09	19,05	23,83	27,79	31,75	35,71	14 x 12
8,38	10,31	14,27	17,48	21,44	25,40	28,57	33,32	
103,00	114,00	141,00	143,00	206,00	235,00	275,00	300,00	
9,52	11,12	15,09	19,05	23,83	27,79	31,75	35,71	14 x 10
7,80	9,27	12,70	15,09	18,26	21,44	25,40	28,57	
99,00	109,00	136,00	141,00	195,00	230,00	265,00	285,00	
9,52	11,12	15,09	19,05	23,83	27,79	31,75	35,71	14 x 8
7,03	8,18	10,31	12,70	15,09	18,26	20,62	23,01	
99,00	109,00	136,00	122,00	195,00	220,00	250,00	270,00	
	11,12		19,05		27,79		35,71	14 x 6
	7,11		10,97		14,27		18,26	
	109,00		122,00		205,00		270,00	
9,52	12,70	16,66	21,44	26,19	30,96	36,53	40,49	16 x 14
9,52	11,12	15,09	19,05	23,83	27,79	31,75	35,71	
119,00	167,00	208,00	200,00	260,00	320,00	360,00	410,00	
9,52	12,70	16,66	21,44	26,19	30,96	36,53	40,49	16 x 12
8,38	10,31	14,27	17,48	21,44	25,40	28,57	33,32	
110,00	161,00	181,00	181,00	250,00	310,00	340,00	385,00	

* Outlet dimension M for NPS ≥ 14" is recommended but not required
Weights are approximate.



tés réduits

ASME B 16.9-1993

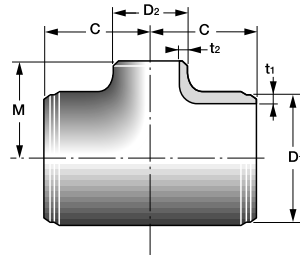

reducing outlet tees

ASME B 16.9-1993

Diamètre Nominal Nominal Pipe Size (NPS)	Dia. extérieur au chanfrein Outside diameter at bevel	Encombrement Center-to-end		STD	E.F. X.S.	X.E.F. X.X.S.	SCH 10	SCH 20	
		C – mm	M – mm	t ₁ ép./W.T. mm					
Pouces/Inches	D – mm	C – mm	M – mm	t ₂ ép./W.T. mm					
masse/weight kg									
16 x 10	406	305	283	9,52	12,70			7,92	
	273			9,27	12,70			6,35	
				116,00	160,00			98,00	
16 x 8	406	305	273	9,52	12,70			7,92	
	219			8,18	12,70			6,35	
				116,00	160			98,00	
16 x 6	406	305	264	9,52	12,70				
	168			7,11	10,97				
				116,00	160				
18 x 16	457	343	330	9,52	12,70		6,35	7,92	
	406			9,52	12,70		6,35	7,92	
				135,00	190,00		105,00	127,00	
18 x 14	457	343	330	9,52	12,70		6,35	7,92	
	356			9,52	12,70		6,35	7,92	
				135,00	190,00		105,00	127,00	
18 x 12	457	343	321	9,52	12,70			7,92	
	324			9,52	12,70			6,35	
				135,00	164,00			127,00	
18 x 10	457	343	308	9,52	12,70			7,92	
	273			9,27	12,70			6,35	
				129,00	164,00			123,00	
18 x 8	457	343	298	9,52	12,70			7,92	
	219			8,18	12,70			6,35	
				129,00	154,00			123,00	
20 x 18	508	381	368	9,52	12,70		6,35	9,52	
	457			9,52	12,70		6,35	7,92	
				168,00	218,00		112,00	168,00	
20 x 16	508	381	356	9,52	12,70		6,35	9,52	
	406			9,52	12,70		6,35	7,92	
				168,00	218,00		112,00	168,00	

Les masses indiquées sont approximatives.

SCH 30	SCH 40	SCH 60	SCH 80	SCH 100	SCH 120	SCH 140	SCH 160	Diamètre Nominal Nominal Pipe Size (NPS)
t ₁ ép./W.T. mm								
t ₂ ép./W.T. mm								Pouces/Inches
masse/weight kg								
9,52	12,70	16,66	21,44	26,19	30,96	36,53	40,49	16 x 10
7,80	9,27	12,70	15,09	18,26	21,44	25,40	28,57	
107,00	160,00	163,00	163,00	210,00	295,00	310,00	360,00	
9,52	12,70	16,66	21,44	26,19	30,96	36,53	40,49	16 x 8
7,03	8,18	10,31	12,70	15,09	18,26	20,62	23,01	
107,00	160,00	161,00	163,00	210,00	280,00	295,00	295,00	
	12,70		21,44		30,96		40,49	16 x 6
	7,11		10,97		14,27		18,26	
	160,00		163,00		250,00		295,00	
11,12	14,27	19,05	23,83	29,36	34,93	39,67	45,24	18 x 16
9,52	12,70	16,66	21,44	26,19	30,96	36,53	40,49	
164,00	238,00	257,00	279,00	380,00	440,00	475,00	550,00	
11,12	14,27	19,05	23,83	29,36	34,93	39,67	45,24	18 x 14
9,52	11,12	15,09	19,05	23,83	27,79	31,75	35,71	
164,00	194,00	212,00	258,00	370,00	420,00	455,00	520,00	
11,12	14,27	19,05	23,83	29,36	34,93	39,67	45,24	18 x 12
8,38	10,31	14,27	17,48	21,44	25,40	28,57	33,32	
154,00	194,00	212,00	234,00	325,00	410,00	410,00	500,00	
11,12	14,27	19,05	23,83	29,36	34,93	39,67	45,24	18 x 10
7,80	9,27	12,70	15,09	18,26	21,44	25,40	28,57	
140,00	150,00	188,00	225,00	325,00	385,00	385,00	475,00	
11,12	14,27	19,05	23,83	29,36	34,93	39,67	45,24	18 x 8
7,03	8,18	10,31	12,70	15,09	18,26	20,62	23,01	
140,00	150,00	188,00	205,00	310,00	360,00	360,00	455,00	
12,70	15,09	20,62	26,18	32,54	38,10	44,45	50,01	20 x 18
11,12	14,27	19,05	23,83	29,36	34,93	39,67	45,24	
218,00	265,00	351,00	410,00	540,00	570,00	680,00	770,00	
12,70	15,09	20,62	26,18	32,54	38,10	44,45	50,01	20 x 16
9,52	12,70	16,66	21,44	26,19	30,96	36,53	40,49	
218,00	230,00	324,00	355,00	470,00	550,00	630,00	750,00	

Weights are approximate.



tés réduits

ASME B 16.9-1993

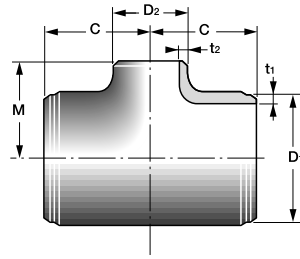

reducing outlet tees

ASME B 16.9-1993

Diamètre Nominal Nominal Pipe Size (NPS)	Dia. extérieur au chanfrein Outside diameter at bevel	Encombrement Center-to-end		STD	E.F. X.S.	X.E.F. X.X.S.	SCH 10	SCH 20	
		C – mm	M – mm	t ₁ ép./W.T. mm		t ₂ ép./W.T. mm		masse/weight kg	
Pouces/Inches	D – mm	C – mm	M – mm						
20 x 14	508	381	356	9,52	12,70		6,35	9,52	
	356			9,52	12,70		6,35	7,92	
				163,00	214,00		110,00	164,00	
20 x 12	508	381	346	9,52	12,70			9,52	
	324			9,52	12,70			6,35	
				163,00	214,00			164,00	
20 x 10	508	381	333	9,52	12,70			9,52	
	273			9,27	12,70			6,35	
				163,00	214,00			164,00	
20 x 8	508	381	324	9,52	12,70			9,52	
	219			8,18	12,70			6,35	
				163,00	214,00			164,00	
22 x 20	559	419	406	9,52	12,70		6,35	9,52	
	508			9,52	12,70		6,35	9,52	
				220,00	280,00		210,00	220,00	
22 x 18	559	419	394	9,52	12,70		6,35	9,52	
	457			9,52	12,70		6,35	7,92	
				209,00	260,00		190,00	209,00	
22 x 16	559	419	381	9,52	12,70		6,35	9,52	
	400			9,52	12,70		6,35	7,92	
				209,00	260,00		190,00	209,00	
22 x 14	559	419	381	9,52	12,70		6,35	9,52	
	356			9,52	12,70		6,35	7,92	
				172,00	245,00		160,00	173,00	
22 x 12	559	419	371	9,52	12,70			9,52	
	324			9,52	12,70			6,35	
				172,00	245,00			173,00	
22 x 10	559	419	359	9,52	12,70			9,52	
	273			9,27	12,70			6,35	
				172,00	245,00			173,00	

Les masses indiquées sont approximatives.

SCH 30	SCH 40	SCH 60	SCH 80	SCH 100	SCH 120	SCH 140	SCH 160	Diamètre Nominal Nominal Pipe Size (NPS)
t ₁ ép./W.T. mm		t ₂ ép./W.T. mm		masse/weight kg				
								Pouces/Inches
12,70	15,09	20,62	26,18	32,54	38,10	44,45	50,01	20 x 14
9,52	11,12	15,09	19,05	23,83	27,79	31,75	35,71	
214,00	224,00	293,00	324,00	470,00	530,00	590,00	725,00	
12,70	15,09	20,62	26,18	32,54	38,10	44,45	50,01	20 x 12
8,38	10,31	14,27	17,48	21,44	25,40	28,57	33,32	
214,00	224,00	293,00	324,00	450,00	500,00	540,00	700,00	
12,70	15,09	20,62	26,18	32,54	38,10	44,45	50,01	20 x 10
7,80	9,27	12,70	15,09	18,26	21,44	25,40	28,57	
214,00	220,00	286,00	293,00	420,00	475,00	500,00	680,00	
12,70	15,09	20,62	26,18	32,54	38,10	44,45	50,01	20 x 8
7,03	8,18	10,31	12,70	15,09	18,26	20,62	23,01	
214,00	220,00	224,00	228,00	390,00	430,00	450,00	660,00	
12,70		22,22	28,58	34,92	41,27	47,62	53,97	22 x 20
12,70		20,62	26,18	32,54	38,10	44,45	50,01	
280,00		445,00	513,00	725,00	820,00	910,00	1020,00	
12,70		22,22	28,58	34,92	41,27	47,62	53,97	22 x 18
11,12		19,05	23,83	29,36	34,93	39,67	45,24	
260,00		390,00	415,00	642,00	780,00	840,00	965,00	
12,70		22,22	28,58	34,92	41,27	47,62	53,97	22 x 16
9,52		16,66	21,44	26,19	30,96	36,53	40,49	
260,00		390,00	415,00	642,00	780,00	840,00	965,00	
12,70		22,22	28,58	34,92	41,27	47,62	53,97	22 x 14
9,52		15,09	19,05	23,83	27,79	31,75	35,71	
245,00		337,00	374,00	525,00	695,00	725,00	860,00	
12,70		22,22	28,58	34,92	41,27	47,62	53,97	22 x 12
8,38		14,27	17,48	21,44	25,40	28,57	33,32	
245,00		337,00	374,00	525,00	695,00	725,00	860,00	
12,70		22,22	28,58	34,92	41,27	47,62	53,97	22 x 10
7,80		12,70	15,09	18,26	21,44	25,40	28,57	
245,00		337,00	374,00	525,00	695,00	725,00	860,00	

Weights are approximate.



tés réduits

ASME B 16.9-1993

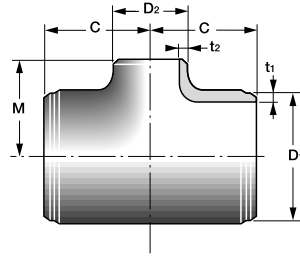

reducing outlet tees

ASME B 16.9-1993

Diamètre Nominal Nominal Pipe Size (NPS)	Dia. extérieur au chanfrein Outside diameter at bevel	Encombrement Center-to-end		STD	E.F. X.S.	X.E.F. X.X.S.	SCH 10	SCH 20	
		C – mm	M – mm	t ₁ ép./W.T. mm					
Pouces/Inches	D – mm	C – mm	M – mm	t ₂ ép./W.T. mm					
masse/weight kg									
24 x 22	610	432	432	9,52	12,70		6,35		Voir STD
	559			9,52	12,70		6,35		
				227,00	350,00		151,00		
24 x 20	610	432	432	9,52	12,70		6,35		Refer to STD
	508			9,52	12,70		6,35		
				227,00	350,00		151,00		
24 x 18	610	432	419	9,52	12,70		6,35	9,52	
	457			9,52	12,70		6,35	7,92	
				227,00	320,00		151,00	227,00	
24 x 16	610	432	406	9,52	12,70		6,35	9,52	
	406			9,52	12,70		6,35	7,92	
				222,00	320,00		150,00	222,00	
24 x 14	610	432	406	9,52	12,70		6,35	9,52	
	356			9,52	12,70		6,35	7,92	
				222,00	300,00		150,00	222,00	
24 x 12	610	432	397	9,52	12,70			9,52	
	324			9,52	12,70			6,35	
				218,00	300,00			218,00	
24 x 10	610	432	384	9,52	12,70			9,52	
	273			9,27	12,70			6,35	
				204,00	300,00			204,00	

Les masses indiquées sont approximatives.

SCH 30	SCH 40	SCH 60	SCH 80	SCH 100	SCH 120	SCH 140	SCH 160	Diamètre Nominal Nominal Pipe Size (NPS)
t ₁ ép./W.T. mm								Pouces/Inches
t ₂ ép./W.T. mm								
masse/weight kg								
14,27		24,61	30,96	38,89	46,02	52,37	59,54	24 x 22
12,70		22,22	28,58	34,92	41,27	47,62	53,97	
373,00		595,00	675,00	910,00	1080,00	1160,00	1290,00	24 x 20
14,27	17,48	24,61	30,96	38,89	46,02	52,37	59,54	
12,70	15,09	20,62	26,19	33,54	38,10	44,45	50,01	24 x 18
373,00	390,00	545,00	606,00	910,00	1060,00	1140,00	1270,00	
14,27	17,48	24,61	30,96	38,89	46,02	52,37	59,54	24 x 16
11,12	14,27	19,05	23,83	29,36	34,93	39,67	45,24	
340,00	390,00	472,00	533,00	815,00	1040,00	1090,00	1210,00	24 x 14
14,27	17,48	24,61	30,96	38,89	46,02	52,37	59,54	
9,52	12,70	16,66	21,44	26,19	30,96	36,53	40,49	24 x 12
340,00	309,00	427,00	490,00	815,00	1010,00	1040,00	1180,00	
14,27	17,48	24,61	30,96	38,89	46,02	52,37	59,54	24 x 10
9,52	11,13	15,09	19,05	23,83	27,79	31,75	35,71	
320,00	309,00	427,00	490,00	770,00	1000,00	1050,00	1140,00	24 x 10
14,27	17,48	24,61	30,96	38,89	46,02	52,37	59,54	
8,38	10,31	14,27	17,48	21,44	25,40	28,57	33,32	24 x 10
320,00	308,00	389,00	452,00	770,00	950,00	980,00	1090,00	
14,27	17,48	24,61	30,96	38,89	46,02	52,37	59,54	24 x 10
7,80	9,27	12,70	15,09	18,26	21,44	25,40	28,57	
320,00	308,00	389,00	452,00	635,00	920,00	950,00	1040,00	

Weights are approximate.



tés réduits

ASME B 16.9-1993

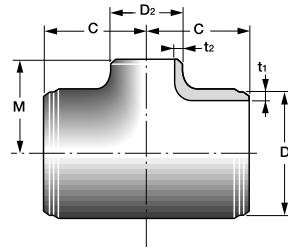

reducing outlet tees

ASME B 16.9-1993

Diamètre Nominal Nominal Pipe Size (NPS)	Dia. extérieur au chanfrein Outside diameter at bevel	Encombrement Center-to-end		STD	E.F. X.S.	SCH 10	SCH 20	SCH 30
		C – mm	M – mm	t ₁ ép./W.T. mm				
Pouces/Inches	D – mm	C – mm	M – mm	t ₂ ép./W.T. mm				
masse/weight kg								
26 x 24	660	495	483	9,52	12,70	7,92	12,70	
	610			9,52	12,70	6,35	9,52	
				280,00	350,00	234,00	350,00	
26 x 22	660	495	470	9,52	12,70	7,92	12,70	
	559			9,52	12,70	6,35	9,52	
				272,00	340,00	234,00	340,00	
26 x 20	660	495	457	9,52	12,70	7,92	12,70	
	508			9,52	12,70	6,35	9,52	
				264,00	330,00	219,00	330,00	
26 x 18	660	495	444	9,52	12,70	7,92	12,70	
	457			9,52	12,70	6,35	7,92	
				255,00	323,00	212,00	320,00	
26 x 16	660	495	432	9,52	12,70	7,92	12,70	
	406			9,52	12,70	6,35	7,92	
				247,00	309,00	205,00	309,00	
26 x 14	660	495	432	9,52	12,70	7,92	12,70	
	356			9,52	12,70	6,35	7,92	
				239,00	300,00	199,00	300,00	
26 x 12	660	495	422	9,52	12,70		12,70	
	324			9,52	12,70		6,35	
				231,00	293,00		293,00	
28 x 26	711	521	521	9,52	12,70	7,92	12,70	
	660			9,52	12,70	7,92	12,70	
				325,00	410,00	271,00	410,00	
28 x 24	711	521	508	9,52	12,70	7,92	12,70	15,88
	610			9,52	12,70	6,35	9,52	14,27
				320,00	400,00	266,00	400,00	480,00
28 x 22	711	521	495	9,52	12,70	7,92	12,70	15,88
	559			9,52	12,70	6,35	9,52	12,70
				311,00	390,00	258,00	390,00	461,00
28 x 20	711	521	483	9,52	12,70	7,92	12,70	15,88
	508			9,52	12,70	6,35	9,52	12,70
				302,00	380,00	251,00	380,00	461,00
28 x 18	711	521	470	9,52	12,70	7,92	12,70	15,88
	457			9,52	12,70	6,35	7,92	11,13
				292,00	369,00	243,00	369,00	461,00

Les masses indiquées sont approximatives.

Diamètre Nominal Nominal Pipe Size (NPS)	Dia. extérieur au chanfrein Outside diameter at bevel	Encombrement Center-to-end		STD	E.F. X.S.	SCH 10	SCH 20	SCH 30
		C – mm	M – mm	t ₁ ép./W.T. mm				
Pouces/Inches	D – mm	C – mm	M – mm	t ₂ ép./W.T. mm				
masse/weight kg								
28 x 16	711	521	457	9,52	12,70	7,92	12,70	15,88
	406			9,52	12,70	6,35	7,92	9,52
				283,00	357,00	235,00	357,00	450,00
28 x 14	711	521	457	9,52	12,70	7,92	12,70	15,88
	356			9,52	12,70	6,35	7,92	9,52
				274,00	346,00	228,00	346,00	450,00
28 x 12	711	521	448	9,52	12,70		12,70	15,88
	324			9,52	12,70		6,35	8,38
30 x 28	762	559	546	9,52	12,70	7,92	12,70	15,88
	711			9,52	12,70	7,92	12,70	15,88
				380,00	475,00	315,00	475,00	566,00
30 x 26	762	559	546	9,52	12,70	7,92	12,70	
	660			9,52	12,70	7,92	12,70	
				372,00	463,00	308,00	463,00	
30 x 24	762	559	533	9,52	12,70	7,92	12,70	15,88
	610			9,52	12,70	6,35	9,52	14,27
				361,00	452,00	300,00	451,00	541,00
30 x 22	762	559	521	9,52	12,70	7,92	12,70	15,88
	559			9,52	12,70	6,35	9,52	12,70
				351,00	441,00	291,00	440,00	500,00
30 x 20	762	559	508	9,52	12,70	7,92	12,70	15,88
	508			9,52	12,70	6,35	9,52	12,70
				340,00	429,00	283,00	428,00	500,00
30 x 18	762	559	495	9,52	12,70	7,92	12,70	15,88
	457			9,52	12,70	6,35	7,92	11,13
				330,00	417,00	274,00	417,00	500,00
30 x 16	762	559	483	9,52	12,70	7,92	12,70	15,88
	406			9,52	12,70	6,35	7,92	9,52
				321,00	405,00	266,00	404,00	470,00
30 x 14	762	559	483	9,52	12,70	7,92	12,70	15,88
	356			9,52	12,70	6,35	7,92	9,52
				312,00	395,00	257,00	392,00	470,00

Weights are approximate.



tés réduits

ASME B 16.9-1993

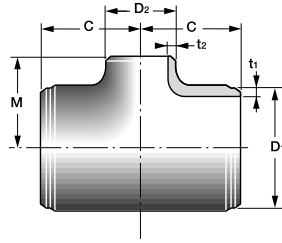

reducing outlet tees

ASME B 16.9-1993

Diamètre Nominal Nominal Pipe Size (NPS)	Dia. extérieur au chanfrein Outside diameter at bevel	Encombrement Center-to-end		STD	E.F. X.S.	SCH 10	SCH 20	SCH 30	SCH 40
		C – mm	M – mm	t ₁ ép./W.T. mm					
Pouces/Inches	D – mm	C – mm	M – mm	t ₂ ép./W.T. mm					
masse/weight kg									
30 x 12	762	559	473	9,52	12,70		12,70	15,88	
	324			9,52	12,70		6,35	8,38	
				304,00	385,00				
30 x 10	762	559	460	9,52	12,70		12,70	15,88	
	273			9,52	12,70		6,35	7,80	
				296,00	377,00				
32 x 30	813	597	584	9,52	12,70	7,92	12,70	15,88	
	762			9,52	12,70	7,92	12,70	15,88	
				506,00	628,00	452,00	543,00	652,00	
32 x 28	813	597	572	9,52	12,70	7,92	12,70	15,88	
	711			9,52	12,70	7,92	12,70	15,88	
				493,00	616,00	357,00	536,00	643,00	
32 x 26	813	597	572	9,52	12,70	7,92	12,70		
	660			9,52	12,70	7,92	12,70		
				482,00	605,00	350,00	526,00		
32 x 24	813	597	559	9,52	12,70	7,92	12,70	15,88	17,48
	610			9,52	12,70	6,35	9,52	14,27	17,48
				472,00	591,00	341,00	513,00	616,00	
32 x 22	813	597	546	9,52	12,70	7,92	12,70	15,88	
	559			9,52	12,70	6,35	9,52	12,70	
				460,00	577,00				
32 x 20	813	597	533	9,52	12,70	7,92	12,70	15,88	17,48
	508			9,52	12,70	6,35	9,52	12,70	15,09
				448,00	562,00	338,00	488,00	585,00	
32 x 18	813	597	521	9,52	12,70	7,92	12,70	15,88	17,48
	457			9,52	12,70	6,35	7,92	11,13	14,27
				436,00	547,00	325,00	475,00	570,00	
32 x 16	813	597	508	9,52	12,70	7,92	12,70	15,88	17,48
	406			9,52	12,70	6,35	7,92	9,52	12,70
				425,00	535,00	317,00	461,00	553,00	
32 x 14	813	597	508	9,52	12,70	7,92	12,70	15,88	17,48
	356			9,52	12,70	6,35	7,92	9,52	11,13
				415,00	523,00				

Les masses indiquées sont approximatives.

Diamètre Nominal Nominal Pipe Size (NPS)	Dia. extérieur au chanfrein Outside diameter at bevel	Encombrement Center-to-end		STD	E.F. X.S.	SCH 10	SCH 20	SCH 30	
		C – mm	M – mm	t ₁ ép./W.T. mm					
Pouces/Inches	D – mm	C – mm	M – mm	t ₂ ép./W.T. mm					
masse/weight kg									
34 x 32	864	635	622	9,52	12,70	7,92	12,70	15,88	
	813			9,52	12,70	7,92	12,70	15,88	
				506,00	628,00	419,00	628,00	788,00	
34 x 30	864	635	610	9,52	12,70	7,92	12,70	15,88	
	762			9,52	12,70	7,92	12,70	15,88	
				493,00	616,00	409,00	616,00	768,00	
34 x 28	864	635	597	9,52	12,70	7,92	12,70	15,88	
	711			9,52	12,70	7,92	12,70	15,88	
				482,00	605,00	400,00	605,00	751,00	
34 x 26	864	635	597	9,52	12,70	7,92	12,70		
	660			9,52	12,70	7,92	12,70		
				472,00	591,00	392,00	591,00		
34 x 24	864	635	584	9,52	12,70	7,92	12,70	15,88	
	610			9,52	12,70	6,35	9,52	14,27	
				460,00	577,00	382,00	576,00	720,00	
34 x 22	864	635	572	9,52	12,70	7,92	12,70	15,88	
	559			9,52	12,70	6,35	9,52	12,70	
				448,00	562,00	372,00	562,00	666,00	
34 x 20	864	635	559	9,52	12,70	7,92	12,70	15,88	
	508			9,52	12,70	6,35	9,52	12,70	
				436,00	547,00	362,00	547,00	666,00	
34 x 18	864	635	546	9,52	12,70	7,92	12,70	15,88	
	457			9,52	12,70	6,35	7,92	11,13	
				425,00	535,00	354,00	533,00	666,00	
34 x 16	864	635	533	9,52	12,70	7,92	12,70	15,88	
	406			9,52	12,70	6,35	7,92	9,52	
				415,00	523,00	343,00	519,00	650,00	
36 x 34	914	673	660	9,52	12,70	7,92	12,70	15,88	
	864			9,52	12,70	7,92	12,70	15,88	
				574,00	715,00	477,00	715,00	893,00	
36 x 32	914	673	648	9,52	12,70	7,92	12,70	15,88	
	813			9,52	12,70	7,92	12,70	15,88	
				561,00	700,00	467,00	700,00	873,00	

Weights are approximate.



tés réduits

ASME B 16.9-1993

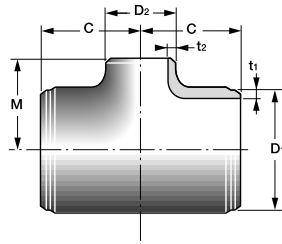

reducing outlet tees

ASME B 16.9-1993

Diamètre Nominal Nominal Pipe Size (NPS)	Dia. extérieur au chanfrein Outside diameter at bevel	Encombrement Center-to-end		STD	E.F. X.S.	SCH 10	SCH 20	SCH 30
		C – mm	M – mm	t ₁ ép./W.T. mm				
Pouces/Inches	D – mm	C – mm	M – mm	t ₂ ép./W.T. mm				
masse/weight kg								
36 x 30	914	673	635	9,52	12,70	7,92	12,70	15,88
	762			9,52	12,70	7,92	12,70	15,88
				548,00	685,00	455,00	685,00	856,00
36 x 28	914	673	622	9,52	12,70	7,92	12,70	15,88
	711			9,52	12,70	7,92	12,70	15,88
				537,00	670,00	446,00	670,00	836,00
36 x 26	914	673	622	9,52	12,70	7,92	12,70	
	660			9,52	12,70	7,92	12,70	
				526,00	654,00	437,00	654,00	
36 x 24	914	673	610	9,52	12,70	7,92	12,70	15,88
	610			9,52	12,70	6,35	9,52	14,27
				513,00	643,00	426,00	642,00	803,00
36 x 22	914	673	597	9,52	12,70	7,92	12,70	15,88
	559			9,52	12,70	6,35	9,52	12,70
				502,00	622,00	415,00	622,00	782,00
36 x 20	914	673	584	9,52	12,70	7,92	12,70	15,88
	508			9,52	12,70	6,35	9,52	12,70
				493,00	621,00	405,00	610,00	763,00
36 x 18	914	673	572	9,52	12,70	7,92	12,70	15,88
	457			9,52	12,70	6,35	7,92	11,13
				483,00	611,00	394,00	596,00	746,00
36 x 16	914	673	559	9,52	12,70	7,92	12,70	15,88
	406			9,52	12,70	6,35	7,92	9,52
				472,00	602,00	383,00	581,00	726,00
38 x 36	965	711	711	9,52	12,70			
	914			9,52	12,70			
				*	*			
38 x 34	965	711	698	9,52	12,70			
	864			9,52	12,70			
				*	*			
38 x 32	965	711	686	9,52	12,70			
	813			9,52	12,70			
				*	*			

* Masse sur demande

Les masses indiquées sont approximatives

Diamètre Nominal Nominal Pipe Size (NPS)	Dia. extérieur au chanfrein Outside diameter at bevel	Encombrement Center-to-end		STD	E.F. X.S.
		C – mm	M – mm	t ₁ ép./W.T. mm	
Pouces/Inches	D – mm	C – mm	M – mm	t ₂ ép./W.T. mm	
masse/weight kg					
38 x 30	965	711	673	9,52	12,70
	762			9,52	12,70
				*	*
38 x 28	965	711	648	9,52	12,70
	711			9,52	12,70
				*	*
38 x 26	965	711	648	9,52	12,70
	660			9,52	12,70
				*	*
38 x 24	965	711	635	9,52	12,70
	610			9,52	12,70
				*	*
38 x 22	965	711	622	9,52	12,70
	559			9,52	12,70
				*	*
38 x 20	965	711	610	9,52	12,70
	508			9,52	12,70
				*	*
38 x 18	965	711	597	9,52	12,70
	457			9,52	12,70
				*	*
40 x 38	1016	749	749	9,52	12,70
	965			9,52	12,70
				664,00	875,00
40 x 36	1016	749	737	9,52	12,70
	914			9,52	12,70
				659,00	840,00
40 x 34	1016	749	724	9,52	12,70
	864			9,52	12,70
				659,00	840,00
40 x 32	1016	749	711	9,52	12,70
	813			9,52	12,70
				643,00	802,00

* Weights on application

Weights are approximate



tés réduits

ASME B 16.9-1993

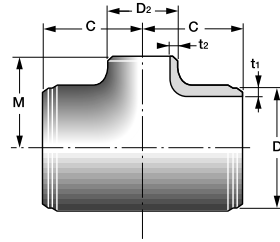

reducing outlet tees

ASME B 16.9-1993

Diamètre Nominal Nominal Pipe Size (NPS)	Dia. extérieur au chanfrein Outside diameter at bevel	Encombrement Center-to-end		STD		E.F. X.S.	
		C – mm	M – mm	t ₁ ép./W.T. mm	t ₂ ép./W.T. mm	mm	mm
Pouces/Inches	D – mm	C – mm	M – mm	masse/weight kg			
40 x 30	1016	749	698	9,52	12,70		
	762			9,52	12,70		
				627,00	763,00		
40 x 28	1016	749	673	9,52	12,70		
	711			9,52	12,70		
				611,00	740,00		
40 x 26	1016	749	673	9,52	12,70		
	660			9,52	12,70		
				595,00	723,00		
40 x 24	1016	749	660	9,52	12,70		
	610			9,52	12,70		
				580,00	700,00		
40 x 22	1016	749	648	9,52	12,70		
	559			9,52	12,70		
				565,00	682,00		
40 x 20	1016	749	635	9,52	12,70		
	508			9,52	12,70		
				552,00	665,00		
40 x 18	1016	749	622	9,52	12,70		
	457			9,52	12,70		
				540,00	650,00		
42 x 40	1067	762	711	9,52	12,70		
	1016			9,52	12,70		
42 x 38	1067	762	711	9,52	12,70		
	965			9,52	12,70		
42 x 36	1067	762	711	9,52	12,70		
	914			9,52	12,70		
				818,00	1045,00		
42 x 34	1067	762	711	9,52	12,70		
	864			9,52	12,70		
				772,00	999,00		

* Masse sur demande

Les masses indiquées sont approximatives.

Diamètre Nominal Nominal Pipe Size (NPS)	Dia. extérieur au chanfrein Outside diameter at bevel	Encombrement Center-to-end		STD		E.F. X.S.	
		C – mm	M – mm	t ₁ ép./W.T. mm	t ₂ ép./W.T. mm	mm	mm
Pouces/Inches	D – mm	C – mm	M – mm	masse/weight kg			
42 x 32	1067	762	711	9,52	12,70		
	813			9,52	12,70		
				772,00	999,00		
42 x 30	1067	762	711	9,52	12,70		
	762			9,52	12,70		
				772,00	999,00		
42 x 28	1067	762	698	9,52	12,70		
	711			9,52	12,70		
				750,00	955,00		
42 x 26	1067	762	698	9,52	12,70		
	660			9,52	12,70		
				750,00	955,00		
42 x 24	1067	762	660	9,52	12,70		
	610			9,52	12,70		
				728,00	915,00		
42 x 22	1067	762	660	9,52	12,70		
	559			9,52	12,70		
				728,00	915,00		
42 x 20	1067	762	660	9,52	12,70		
	508			9,52	12,70		
				708,00	875,00		
42 x 18	1067	762	648	9,52	12,70		
	457			9,52	12,70		
				708,00	875,00		
42 x 16	1067	762	635	9,52	12,70		
	406			9,52	12,70		
				700,00	847,00		
44 x 42	1118	813	762	9,52	12,70		
	1067			9,52	12,70		
				*	*		
44 x 40	1118	813	749	9,52	12,70		
	1016			9,52	12,70		
				*	*		

* Weights on application

Weights are approximate



tés réduits

ASME B 16.9-1993

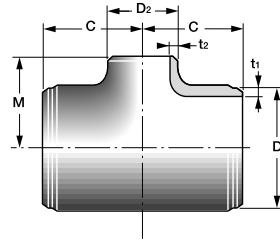

reducing outlet tees

ASME B 16.9-1993

Diamètre Nominal Nominal Pipe Size (NPS)	Dia. extérieur au chanfrein Outside diameter at bevel	Encombrement Center-to-end		STD		E.F. X.S.	
		C – mm	M – mm	t ₁ ép./W.T. mm	t ₂ ép./W.T. mm	mm	mm
Pouces/Inches	D – mm	C – mm	M – mm	masse/weight kg			
44 x 38	1118	813	737	9,52	12,70		
	965			9,52	12,70		
				*	*		
44 x 36	1118	813	724	9,52	12,70		
	914			9,52	12,70		
				*	*		
44 x 34	1118	813	724	9,52	12,70		
	864			9,52	12,70		
				*	*		
44 x 32	1118	813	711	9,52	12,70		
	813			9,52	12,70		
				*	*		
44 x 30	1118	813	711	9,52	12,70		
	762			9,52	12,70		
				*	*		
44 x 28	1118	813	698	9,52	12,70		
	711			9,52	12,70		
				*	*		
44 x 26	1118	813	698	9,52	12,70		
	660			9,52	12,70		
				*	*		
44 x 24	1118	813	698	9,52	12,70		
	610			9,52	12,70		
				*	*		
44 x 22	1118	813	686	9,52	12,70		
	559			9,52	12,70		
				*	*		
44 x 20	1118	813	686	9,52	12,70		
	508			9,52	12,70		
				*	*		

* Masse sur demande

Les masses indiquées sont approximatives

Diamètre Nominal Nominal Pipe Size (NPS)	Dia. extérieur au chanfrein Outside diameter at bevel	Encombrement Center-to-end		STD		E.F. X.S.	
		C – mm	M – mm	t ₁ ép./W.T. mm	t ₂ ép./W.T. mm	mm	mm
Pouces/Inches	D – mm	C – mm	M – mm	masse/weight kg			
46 x 44	1168	851	800	9,52	12,70		
	1118			9,52	12,70		
				*	*		
46 x 42	1168	851	787	9,52	12,70		
	1067			9,52	12,70		
				*	*		
46 x 40	1168	851	775	9,52	12,70		
	1016			9,52	12,70		
				*	*		
46 x 38	1168	851	762	9,52	12,70		
	965			9,52	12,70		
				*	*		
46 x 36	1168	851	762	9,52	12,70		
	914			9,52	12,70		
				*	*		
46 x 34	1168	851	749	9,52	12,70		
	864			9,52	12,70		
				*	*		
46 x 32	1168	851	749	9,52	12,70		
	813			9,52	12,70		
				*	*		
46 x 30	1168	851	737	9,52	12,70		
	762			9,52	12,70		
				*	*		
46 x 28	1168	851	737	9,52	12,70		
	711			9,52	12,70		
				*	*		
46 x 26	1168	851	737	9,52	12,70		
	660			9,52	12,70		
				*	*		

* Weights on application

Weights are approximate



tés réduits

ASME B 16.9-1993

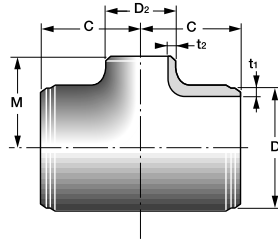

reducing outlet tees

ASME B 16.9-1993

Diamètre Nominal Nominal Pipe Size (NPS)	Dia. extérieur au chanfrein Outside diameter at bevel	Encombrement Center-to-end		STD		E.F. X.S.	
		C – mm	M – mm	t ₁ ép./W.T. mm	t ₂ ép./W.T. mm	mm	mm
Pouces/Inches	D – mm	C – mm	M – mm	masse/weight kg			
46 x 24	1168	851	724	9,52	12,70		
	610			9,52	12,70		
				*	*		
46 x 22	1168	851	724	9,52	12,70		
	559			9,52	12,70		
				*	*		
48 x 46	1219	889	838	9,52	12,70		
	1168			9,52	12,70		
				1090,00	1307,00		
48 x 44	1219	889	838	9,52	12,70		
	1118			9,52	12,70		
				1090,00	1307,00		
48 x 42	1219	889	813	9,52	12,70		
	1067			9,52	12,70		
				1067,00	1272,00		
48 x 40	1219	889	813	9,52	12,70		
	1016			9,52	12,70		
				1067,00	1272,00		
48 x 38	1219	889	813	9,52	12,70		
	965			9,52	12,70		
				1044,00	1238,00		
48 x 36	1219	889	787	9,52	12,70		
	914			9,52	12,70		
				1022,00	1203,00		
48 x 34	1219	889	787	9,52	12,70		
	864			9,52	12,70		
				1022,00	1203,00		
48 x 32	1219	889	787	9,52	12,70		
	813			9,52	12,70		
				1000,00	1170,00		

* Masse sur demande

Les masses indiquées sont approximatives

Diamètre Nominal Nominal Pipe Size (NPS)	Dia. extérieur au chanfrein Outside diameter at bevel	Encombrement Center-to-end		STD		E.F. X.S.	
		C – mm	M – mm	t ₁ ép./W.T. mm	t ₂ ép./W.T. mm	mm	mm
Pouces/Inches	D – mm	C – mm	M – mm	masse/weight kg			
48 x 30	1219	889	762	9,52	12,70		
	762			9,52	12,70		
				1000,00	1170,00		
48 x 28	1219	889	762	9,52	12,70		
	711			9,52	12,70		
				980,00	1140,00		
48 x 26	1219	889	762	9,52	12,70		
	660			9,52	12,70		
				980,00	1140,00		
48 x 24	1219	889	737	9,52	12,70		
	610			9,52	12,70		
				960,00	1115,00		
48 x 22	1219	889	737	9,52	12,70		
	559			9,52	12,70		
				960,00	1115,00		

* Weights on application

Weights are approximate



caps

ASME B 16.9-1993

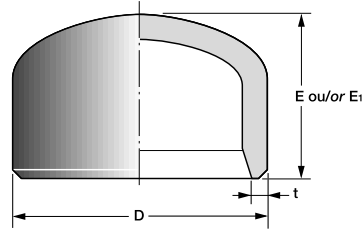

Diamètre Nominal Nominal Pipe Size (NPS)	Diamètre extérieur Outside diameter	Hauteur Length	Ep. limite pour hauteur E Limiting W.T. for length E	Hauteur (*) Length (*)	STD	E.F. X.S.	X.E.F. X.X.S.	SCH 10	SCH 20
					† ép./W.T. mm masse/weight kg				
Pouces/Inches	D – mm	E – mm	mm	E ₁ – mm					
1/2	21	25	3,73	25	2,77 0,03	3,73 0,05	7,47		
3/4	27	25	3,91	25	2,87 0,06	3,91 0,10	7,82		
1	33	38	4,55	38	3,38 0,10	4,55 0,13	9,09 0,20		
1 1/4	42	38	4,85	38	3,56 0,14	4,85 0,20	9,70 0,28		
1 1/2	48	38	5,08	38	3,68 0,20	5,08 0,23	10,16 0,36		
2	60	38	5,54	44	3,91 0,30	5,54 0,30	11,07 0,59		
2 1/2	73	38	7,01	51	5,16 0,50	7,01 0,50	14,02 1,00		
3	89	51	7,62	64	5,49 0,70	7,62 0,90	15,24 1,78		
3 1/2	102	64	8,08	76	5,74 1,40	8,08 1,70			
4	114	64	8,56	76	6,02 1,60	8,56 2,00	17,12 3,17		
5	141	76	9,53	89	6,55 2,30	9,52 3,00	19,05 5,50		
6	168	89	10,97	102	7,11 3,60	10,97 4,00	21,95 8,10		
8	219	102	12,70	127	8,18 5,50	12,70 8,40	22,23 19,50	6,35 4,50	
10	273	127	12,70	152	9,27 10,00	12,70 13,60	25,40 29,30	6,35 7,00	
12	324	152	12,70	178	9,52 15,00	12,70 22,00	25,40 41,00	6,35 9,00	
14	356	165	12,70	191	9,52 17,00	12,70 27,00		6,35 14,00	7,92 15,50

Nota : La forme de ces caps sera ellipsoïdale et conforme aux exigences du code «ASME Boiler and Pressure Vessel». La hauteur E s'applique pour des épaisseurs n'excédant pas celles données par la rubrique «Épaisseur limite pour E».

Les masses indiquées sont approximatives.

(*) La hauteur E₁ s'applique pour des épaisseurs supérieures à celles données par la rubrique «Épaisseur limite» pour NPS 24 et au-dessous. Pour les caps NPS 26 et au-dessus, la hauteur E₁ sera déterminée d'un commun accord entre acheteur et fabricant.



caps

ASME B 16.9-1993

SCH 30	SCH 40	SCH 60	SCH 80	SCH 100	SCH 120	SCH 140	SCH 160	Diamètre Nominal Nominal Pipe Size (NPS)
† ép./W.T. mm masse/weight kg							Pouces/Inches	
2,41							4,78	1/2
2,41							5,56	3/4
2,90							6,35 0,15	1
2,97							6,35 0,23	1 1/4
3,18							7,13 0,30	1 1/2
3,18							8,74 0,55	2
4,78	Voir STD						9,52 0,90	2 1/2
4,78							11,13 1,40	3
4,78	Refer to STD							3 1/2
4,78							11,13 2,31	4
							12,70 3,89	5
							14,27 6,02	6
							15,09 18,26	8
7,03		10,31			15,09	18,26	20,62	23,01
5,00		7,00			11,00	15,50	18,50	20,00
7,80		12,70	15,09		18,26	21,44	25,40	28,57
7,63		13,60	16,20	21,00	24,00	27,00	30,00	
8,38		14,27	17,48	21,44	25,40	28,57	33,32	
13,00	19,00	22,00	26,90	32,50	41,00	42,00	44,50	12
Voir STD	11,13	15,09	19,05	23,83	27,79	31,75	35,71	14
Refer to STD	23,00	32,00	34,70	42,00	47,00	52,00	60,00	

Note : The shape of these caps shall be ellipsoïdale and shall conform to the shape requirements as given in «ASME Boiler and Pressure Vessel» Code. Length E applies for thickness not exceeding that given in column «Limiting wall thickness for length E».

Weights are approximate

(*) Length E₁ applies for thickness greater than that given in column «Limiting wall thickness» for sizes NPS 24 and smaller.

For sizes NPS 26 and larger, length E₁ shall be by agreement between manufacturer and purchaser.



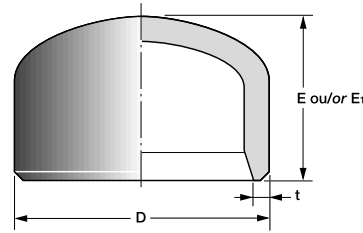

Diamètre Nominal Nominal Pipe Size (NPS)	Diamètre extérieur Outside diameter	Hauteur Length	Ep. limite pour hauteur E Limiting W.T. for length E	Hauteur (*) Length (*)	STD	E.F. X.S.	X.E.F. X.X.S.	SCH 10	SCH 20
					† ép./W.T. mm				masse/weight kg
Pouces/Inches	D – mm	E – mm	mm	E ₁ – mm					
16	406	178	12,70	203	9,52	12,70		6,35	7,92
					23,00	30,00		18,00	20,00
18	457	203	12,70	229	9,52	12,70		6,35	7,92
					29,00	32,00		22,00	25,00
20	508	229	12,70	254	9,52	12,70		6,35	
					36,00	49,00		31,00	
22	559	254	12,70	254	9,52	12,70		6,35	
					42,00	51,00		35,50	
24	610	267	12,70	305	9,52	12,70		6,35	
					52,00	60,00		40,00	
26	660	267			9,52	12,70		7,92	
					46,50	66,00		42,00	
28	711	267			9,52	12,70		7,92	
					56,00	75,00		47,00	
30	762	267			9,52	12,70		7,92	
					62,00	83,00		51,00	
32	813	267			9,52	12,70		7,92	
					68,00	93,00		57,00	
34	864	267			9,52	12,70		7,92	
					73,00	97,00		60,00	
36	914	267			9,52	12,70		7,92	
					79,50	107,00		66,00	
38	965	305			9,52	12,70			
					86,00	125,00			
40	1016	305			9,52	12,70			
					95,00	129,00			
42	1067	305			9,52	12,70			
					104,50	136,50			
44	1118	343			9,52	12,70			
					120,00	168,00			
46	1168	343			9,52	12,70			
					136,00	186,00			
48	1219	343			9,52	12,70			
					159,00	215,00			

Nota : La forme de ces caps sera ellipsoïdale et conforme aux exigences du code «ASME Boiler and Pressure Vessel». La hauteur E s'applique pour des épaisseurs n'excédant pas celles données par la rubrique «Épaisseur limite pour E».

Les masses indiquées sont approximatives.

(*) La hauteur E₁ s'applique pour des épaisseurs supérieures à celles données par la rubrique «Épaisseur limite» pour NPS 24 et au-dessous. Pour les caps NPS 26 et au-dessus, la hauteur E₁ sera déterminée d'un commun accord entre acheteur et fabricant.



SCH 30	SCH 40	SCH 60	SCH 80	SCH 100	SCH 120	SCH 140	SCH 160	Diamètre Nominal Nominal Pipe Size (NPS)
† ép./W.T. mm							Pouces/Inches	
Voir STD	Voir E.F.	16,66	21,44	26,19	30,96	36,53	40,49	16
Refer to STD	Refer to X.S.	37,00	43,50	54,00	64,00	73,00	79,00	
11,13	14,27	19,05	23,83	29,36	34,93	39,67	45,24	18
30,30	39,00	66,00	72,50	75,00	88,00	93,00	104,00	
12,70	15,09	20,62	26,18	32,54	38,10	44,45	50,01	20
49,00	66,70	94,50	98,50	100,00	105,00	153,00	170,00	
12,70		22,22	28,58	34,92	41,27	47,62	53,97	22
59,00		107,00	120,00	135,00	150,00	198,00	220,00	
14,27	17,48	24,61	30,96	38,89	46,02	52,37	59,54	24
74,50	93,00	120,00	150,00	180,00	200,00	250,00	285,00	
								26
15,88								
93,00								28
15,88								
103,00								30
15,88	17,48							
117,00	129,00							32
15,88	17,48							
121,00	133,00							34
15,88	19,05							
134,00	147,00							36
								38
								40
								42
								44
								46
								48

Note : The shape of these caps shall be ellipsoïdale and shall conform to the shape requirements as given in «ASME Boiler and Pressure Vessel» Code. Length E applies for thickness not exceeding that given in column «Limiting wall thickness for length E».

Weights are approximate

(*) Length E₁ applies for thickness greater than that given in column «Limiting wall thickness» for sizes NPS 24 and smaller.

For sizes NPS 26 and larger, length E₁ shall be by agreement between manufacturer and purchaser.



réductions concentriques et excentriques

ASME B 16.9-1993

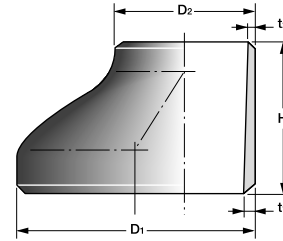
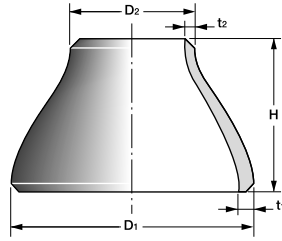

concentric and eccentric reducers

ASME B 16.9-1993

Diamètre Nominal Nominal Pipe Size (NPS)	Dia. extérieur au chanfrein Outside diameter at bevel	Longueur End-to-end length	STD	E.F. X.S.	X.E.F. X.X.S.	SCH 10	SCH 20
			t ₁ ép./W.T. mm			t ₂ ép./W.T. mm	
Pouces/Inches	D – mm	H – mm					
3/4 x 1/2	27	38	2,87	3,91	7,82		
	21		2,77	3,73	7,47		
			0,07	0,10	0,19		
3/4 x 3/8	27	38	2,87	3,91			
	17		2,31	3,20			
			0,07	0,10			
1 x 3/4	33	51	3,38	4,55	9,09		
	27		2,87	3,91	7,82		
			0,13	0,16	0,28		
1 x 1/2	33	51	3,38	4,55	9,09		
	21		2,77	3,73	7,47		
			0,13	0,16	0,28		
1 1/4 x 1	42	51	3,56	4,85	9,70		
	33		3,38	4,55	9,09		
			0,17	0,23	0,39		
1 1/4 x 3/4	42	51	3,56	4,85	9,70		
	27		2,87	3,91	7,82		
			0,17	0,23	0,39		
1 1/4 x 1/2	42	51	3,56	4,85	9,70		
	21		2,77	3,73	7,47		
			0,17	0,23	0,39		
1 1/2 x 1 1/4	48	64	3,68	5,08	10,16		
	42		3,56	4,85	9,70		
			0,26	0,35	0,61		
1 1/2 x 1	48	64	3,68	5,08	10,16		
	33		3,38	4,55	9,09		
			0,26	0,35	0,61		
1 1/2 x 3/4	48	64	3,68	5,08	10,16		
	27		2,87	3,91	7,82		
			0,26	0,35	0,61		
1 1/2 x 1/2	48	64	3,68	5,08	10,16		
	21		2,77	3,73	7,47		
			0,26	0,35	0,61		

Les masses indiquées sont approximatives.

SCH 30	SCH 40	SCH 60	SCH 80	SCH 100	SCH 120	SCH 140	SCH 160	Diamètre Nominal Nominal Pipe Size (NPS)
t ₁ ép./W.T. mm							Pouces/Inches	
t ₂ ép./W.T. mm								masse/weight kg
2,41							5,56	3/4 x 1/2
2,41							4,78	
							0,14	
2,41								3/4 x 3/8
1,85								
2,90							6,35	1 x 3/4
2,41							5,56	
							0,21	
2,90							6,35	1 x 1/2
2,41							4,78	
							0,21	
2,97							6,35	1 1/4 x 1
2,90							6,35	
							0,29	
2,97	Voir STD		Voir E.F.				6,35	1 1/4 x 3/4
2,41							5,56	
2,97	Refer to STD		Refer to X.S.				6,35	1 1/4 x 1/2
2,41							4,78	
3,18							7,13	1 1/2 x 1 1/4
2,97							6,35	
							0,46	
3,18							7,13	1 1/2 x 1
2,90							6,35	
							0,46	
3,18							7,13	1 1/2 x 3/4
2,41							5,56	
							0,46	
3,18							7,13	1 1/2 x 1/2
2,41							4,78	
							0,46	

Weights are approximate.



réductions concentriques et excentriques

ASME B 16.9-1993

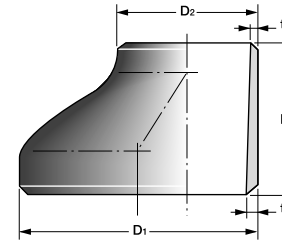
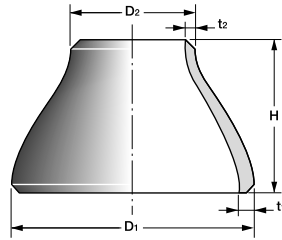

concentric and eccentric reducers

ASME B 16.9-1993

Diamètre Nominal Nominal Pipe Size (NPS)	Dia. extérieur au chanfrein Outside diameter at bevel	Longueur End-to-end length	STD	E.F. X.S.	X.E.F. X.X.S.	SCH 10	SCH 20
			t ₁ ép./W.T. mm			t ₂ ép./W.T. mm	
Pouces/Inches	D – mm	H – mm					
2 x 1 1/2	60	76	3,91	5,54	11,07		
	48		3,68	5,08	10,16		
			0,41	0,57	1,03		
2 x 1 1/4	60	76	3,91	5,54	11,07		
	42		3,56	4,85	9,70		
			0,41	0,57	1,03		
2 x 1	60	76	3,91	5,54	11,07		
	33		3,38	4,55	9,09		
			0,41	0,57	1,03		
2 x 3/4	60	76	3,91	5,54	11,07		
	27		2,87	3,91	7,82		
			0,41	0,57	1,03		
2 1/2 x 2	73	89	5,16	7,01	14,02		
	60		3,91	5,54	11,07		
			0,77	1,01	1,81		
2 1/2 x 1 1/2	73	89	5,16	7,01	14,02		
	48		3,68	5,08	10,16		
			0,77	1,01	1,81		
2 1/2 x 1 1/4	73	89	5,16	7,01	14,02		
	42		3,56	4,85	9,70		
			0,77	1,01	1,81		
2 1/2 x 1	73	89	5,16	7,01	14,02		
	33		3,38	4,55	9,09		
			0,77	1,01	1,81		
3 x 2 1/2	89	89	5,49	7,62	15,24		
	73		5,16	7,01	14,02		
			1,00	4,36	2,47		
3 x 2	89	89	5,49	7,62	15,24		
	60		3,91	5,54	11,07		
			1,00	1,36	2,47		
3 x 1 1/2	89	89	5,49	7,62	15,24		
	48		3,68	5,08	10,16		
			1,00	1,36	2,47		

Les masses indiquées sont approximatives.

SCH 30	SCH 40	SCH 60	SCH 80	SCH 100	SCH 120	SCH 140	SCH 160	Diamètre Nominal Nominal Pipe Size (NPS)
t ₁ ép./W.T. mm								Pouces/Inches
t ₂ ép./W.T. mm								
masse/weight kg								
3,18							8,74	2 x 1 1/2
3,18							7,13	
							0,84	2 x 1 1/4
3,18							8,74	
2,97							6,35	2 x 1
							0,84	
3,18							8,74	2 x 3/4
2,90							6,35	
							0,84	2 1/2 x 2
3,18							8,74	
2,41							5,56	2 1/2 x 1 1/2
							0,84	
4,78							9,52	2 1/2 x 1 1/4
3,18	Voir STD				Voir E.F.		8,74	
							1,33	2 1/2 x 1
4,78							9,52	
3,18							7,13	3 x 2 1/2
							1,33	
4,78	Refer to STD				Refer to X.S.		9,52	3 x 2
2,97							6,35	
							1,33	3 x 1 1/2
4,78							9,52	
2,90							6,35	3 x 1 1/2
							1,33	
4,78							11,13	3 x 1 1/2
4,78							9,52	
							1,89	3 x 1 1/2
4,78							11,13	
3,18							8,74	3 x 1 1/2
							1,89	
4,78							11,13	3 x 1 1/2
3,18							7,13	
							1,89	

Weights are approximate.



réductions concentriques et excentriques

ASME B 16.9-1993

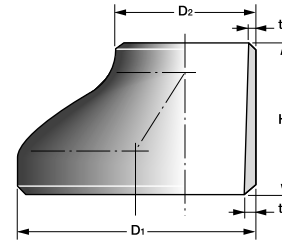
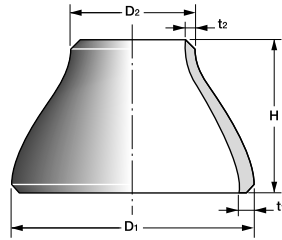

concentric and eccentric reducers

ASME B 16.9-1993

Diamètre Nominal Nominal Pipe Size (NPS)	Dia. extérieur au chanfrein Outside diameter at bevel	Longueur End-to-end length	STD	E.F. X.S.	X.E.F. X.X.S.	SCH 10	SCH 20	
			t ₁ ép./W.T. mm		t ₂ ép./W.T. mm		masse/weight kg	
Pouces/Inches	D – mm	H – mm						
3 x 1 1/4	89	89	5,49	7,62	15,24			
	42		3,56	4,85	9,70			
			1,00	1,36	2,47			
3 1/2 x 3	102	102	5,74	8,08				
	89		5,49	7,62				
			1,40	1,89				
3 1/2 x 2 1/2	102	102	5,74	8,08				
	73		5,16	7,01				
			1,40	1,89				
3 1/2 x 2	102	102	5,74	8,08				
	60		3,91	5,54				
			1,40	1,89				
3 1/2 x 1 1/2	102	102	5,74	8,08				
	48		3,68	5,08				
			1,40	1,89				
3 1/2 x 1 1/4	102	102	5,74	8,08				
	42		3,56	4,85				
			1,40	1,89				
4 x 3 1/2	114	102	6,02	8,56				
	102		5,74	8,08				
			1,60	2,27				
4 x 3	114	102	6,02	8,56	17,12			
	89		5,49	7,62	15,24			
			1,60	2,27	4,18			
4 x 2 1/2	114	102	6,02	8,56	17,12			
	73		5,16	7,01	14,02			
			1,60	2,27	4,18			
4 x 2	114	102	6,02	8,56	17,12			
	60		3,91	5,54	11,07			
			1,60	2,27	4,18			
4 x 1 1/2	114	102	6,02	8,56	17,12			
	48		3,68	5,08	10,16			
			1,60	2,27	4,18			

Les masses indiquées sont approximatives.

SCH 30	SCH 40	SCH 60	SCH 80	SCH 100	SCH 120	SCH 140	SCH 160	Diamètre Nominal Nominal Pipe Size (NPS)
t ₁ ép./W.T. mm								Pouces/Inches
t ₂ ép./W.T. mm								
masse/weight kg								
4,78							11,13	3 x 1 1/4
2,97							6,35	
							1,89	
4,78								3 1/2 x 3
4,78								
4,78								3 1/2 x 2 1/2
4,78								
4,78								3 1/2 x 2
3,18								
4,78								3 1/2 x 1 1/2
3,18								
4,78								3 1/2 x 1 1/4
2,97								
4,78								4 x 3 1/2
4,78								
4,78							13,50	4 x 3
4,78							11,13	
4,78							3,41	4 x 2 1/2
4,78							13,50	
4,78							9,52	4 x 2
3,18							3,41	
4,78							13,50	4 x 1 1/2
3,18							8,74	
4,78							13,50	4 x 1 1/2
3,18							7,13	
							3,41	

Weights are approximate.



réductions concentriques et excentriques

ASME B 16.9-1993

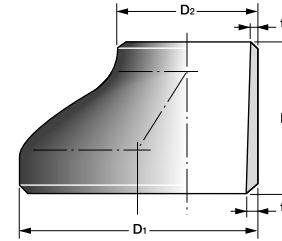
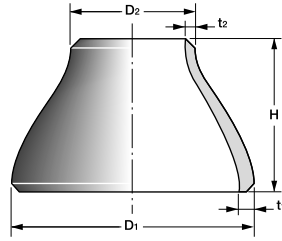

concentric and eccentric reducers

ASME B 16.9-1993

Diamètre Nominal Nominal Pipe Size (NPS)	Dia. extérieur au chanfrein Outside diameter at bevel	Longueur End-to-end length	STD	E.F. X.S.	X.E.F. X.X.S.	SCH 10	SCH 20	
			t ₁ ép./W.T. mm		t ₂ ép./W.T. mm		masse/weight kg	
Pouces/Inches	D – mm	H – mm						
5 x 4	141	127	6,55	9,52	19,05			
	114		6,02	8,56	17,12			
			2,80	3,93	7,31			
5 x 3 1/2	141	127	6,55	9,52				
	102		5,74	8,08				
			2,80	3,93				
5 x 3	141	127	6,55	9,52	19,05			
	89		5,49	7,62	15,24			
			2,80	3,93	7,31			
5 x 2 1/2	141	127	6,35	9,52	19,05			
	73		5,16	7,01	14,02			
			2,80	3,93	7,31			
5 x 2	141	127	6,55	9,52	19,05			
	60		3,91	5,54	11,07			
			2,80	3,93	7,31			
6 x 5	168	140	7,11	10,97	21,95			
	141		6,55	9,52	19,05			
			3,90	5,95	11,08			
6 x 4	168	140	7,11	10,97	21,95			
	114		6,02	8,56	17,12			
			3,90	5,95	11,08			
6 x 3 1/2	168	140	7,11	10,97				
	102		5,74	8,08				
			3,90	5,95				
6 x 3	168	140	7,11	10,97	21,95			
	89		5,49	7,62	15,24			
			3,90	5,95	11,08			
6 x 2 1/2	168	140	7,11	10,97	21,95			
	73		5,16	7,01	14,02			
			3,90	5,95	11,08			

Les masses indiquées sont approximatives.

SCH 30	SCH 40	SCH 60	SCH 80	SCH 100	SCH 120	SCH 140	SCH 160	Diamètre Nominal Nominal Pipe Size (NPS)
t ₁ ép./W.T. mm		t ₂ ép./W.T. mm		masse/weight kg		Pouces/Inches		
					12,70		15,87	5 x 4
					11,13		13,50	
					5,68		6,26	
								5 x 3 1/2
							15,87	5 x 3
							11,13	
							6,26	
							15,87	5 x 2 1/2
							9,52	
							6,26	
	Voir STD		Voir E.F.				15,87	5 x 2
							8,74	
							6,26	
	Refer to STD		Refer to X.S.		14,27		18,26	6 x 5
					12,70		15,87	
					7,58		9,40	
					14,27		18,26	6 x 4
					11,13		13,50	
					7,58		9,40	
								6 x 3 1/2
							18,26	6 x 3
							11,13	
							9,40	
							18,26	6 x 2 1/2
							9,52	
							9,40	

Weights are approximate.



réductions concentriques et excentriques

ASME B 16.9-1993

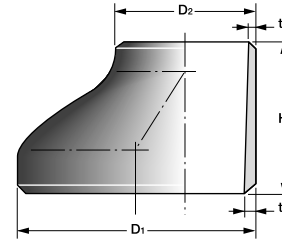
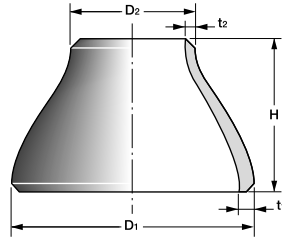

concentric
and eccentric
reducers

ASME B 16.9-1993

Diamètre Nominal Nominal Pipe Size (NPS)	Dia. extérieur au chanfrein Outside diameter at bevel	Longueur End-to-end length	STD	E.F. X.S.	X.E.F. X.X.S.	SCH 10	SCH 20	
			t ₁ ép./W.T. mm		t ₂ ép./W.T. mm		masse/weight kg	
Pouces/Inches	D – mm	H – mm						
8 x 6	219	152	8,18	12,70	22,23			
	168		7,11	10,97	21,95			
8 x 5	219	152	8,18	12,70	22,23			
	141		6,55	9,52	19,05			
8 x 4	219	152	8,18	12,70	22,23			
	114		6,02	8,56	17,12			
8 x 3 1/2	219	152	8,18	12,70				
	102		5,74	8,08				
10 x 8	273	178	9,27	12,70	25,40		6,35	
	219		8,18	12,70	22,23		6,35	
10 x 6	273	178	9,27	12,70	25,40			
	168		7,11	10,97	21,95			
10 x 5	273	178	9,27	12,70	25,40			
	141		6,55	9,52	19,05			
10 x 4	273	178	9,27	12,70	25,40			
	114		6,02	8,56	17,12			
12 x 10	324	203	9,52	12,70	25,40		6,35	
	273		9,27	12,70	25,40		6,35	
12 x 8	324	203	15,00	19,80	42,00		10,16	
	219		9,52	12,70	25,40		6,35	
			8,18	12,70	22,23		6,35	
			15,00	19,80	40,00		10,16	

Les masses indiquées sont approximatives.

SCH 30	SCH 40	SCH 60	SCH 80	SCH 100	SCH 120	SCH 140	SCH 160	Diamètre Nominal Nominal Pipe Size (NPS)
t ₁ ép./W.T. mm		t ₂ ép./W.T. mm		masse/weight kg				
								Pouces/Inches
					18,26		23,01	8 x 6
					14,27		18,26	
					13,70		16,90	8 x 5
			Voir E.F.		18,26		23,01	
					12,70		15,87	8 x 4
					13,70		16,90	
			Refer to X.S.		18,26		23,01	8 x 3 1/2
					11,13		13,50	
					13,70		16,90	
	Voir STD							
7,80								10 x 8
7,03	Refer to STD	12,70	15,09	18,26	21,44	25,40	28,57	
9,00		10,31	12,70	15,09	18,26	20,62	23,01	10 x 6
		14,50	17,00	20,40	23,60	27,50	30,60	
								10 x 5
					15,09		28,57	
					10,97		18,26	10 x 4
					17,00		30,60	
					15,09		28,57	12 x 10
					9,52		15,87	
					17,00		30,60	12 x 8
					15,09		28,57	
8,38	10,31	14,27	17,48	21,44	25,40	28,57	33,32	12 x 10
7,80	9,27	12,70	15,09	18,26	21,44	25,40	28,57	
13,20	16,30	22,20	26,80	32,40	38,00	42,30	48,60	12 x 8
8,38	10,31	14,27	17,48	21,44	25,40	28,57	33,32	
7,03	8,18	10,31	12,70	15,09	18,26	20,62	23,01	12 x 8
13,20	16,30	22,20	26,80	32,40	38,00	42,30	48,60	

Weights are approximate.



réductions concentriques et excentriques

ASME B 16.9-1993

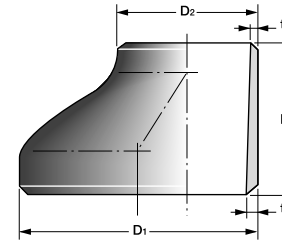
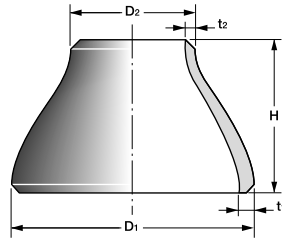

concentric and eccentric reducers

ASME B 16.9-1993

Diamètre Nominal Nominal Pipe Size (NPS)	Dia. extérieur au chanfrein Outside diameter at bevel	Longueur End to end length	STD	E.F. X.S.	X.E.F. X.X.S.	SCH 10	SCH 20	
			t ₁ ép./W.T. mm					
Pouces/Inches	D – mm	H – mm	t ₂ ép./W.T. mm					
			masse/weight kg					
12 x 6	324	203	9,52	12,70	25,40			
	168		7,11	10,97	21,95			
			15,00	19,80	39,00			
12 x 5	324	203	9,52	12,70	25,40			
	141		6,55	9,52	19,05			
			15,00	19,80	38,00			
14 x 12	356	330	9,52	12,70			7,92	
	324		9,52	12,70			6,35	
			26,90	35,50			22,60	
14 x 10	356	330	9,52	12,70			7,92	
	273		9,27	12,70			6,35	
			26,90	35,50			22,60	
14 x 8	356	330	9,52	12,70			7,92	
	219		8,18	12,70			6,35	
			26,90	35,50			22,60	
14 x 6	356	330	9,52	12,70				
	168		7,11	10,97				
			26,90	35,50				
16 x 14	406	356	9,52	12,70		6,35	7,92	
	356		9,52	12,70		6,35	7,92	
			33,00	44,00		28,00	27,90	
16 x 12	406	356	9,52	12,70			7,92	
	324		9,52	12,70			6,35	
			33,00	44,00			27,90	
16 x 10	406	356	9,52	12,70			7,92	
	273		9,27	12,70			6,35	
			33,00	44,00			27,90	
16 x 8	406	356	9,52	12,70			7,92	
	219		8,18	12,70			6,35	
			33,00	44,00			27,90	

Les masses indiquées sont approximatives.

SCH 30	SCH 40	SCH 60	SCH 80	SCH 100	SCH 120	SCH 140	SCH 160	Diamètre Nominal Nominal Pipe Size (NPS)
t ₁ ép./W.T. mm								
t ₂ ép./W.T. mm								Pouces/Inches
masse/weight kg								
	10,31		17,48		25,40		33,32	12 x 6
	7,11		10,97		14,27		18,26	
	16,30		26,80		38,00		48,60	
	10,31		17,48		25,40		33,32	12 x 5
	6,55		9,52		12,70		15,87	
	16,30		26,80		38,00		48,60	
9,52	11,13	15,09	19,05	23,83	27,79	31,75	35,71	14 x 12
8,38	10,31	14,27	17,48	21,44	25,40	28,57	33,32	
26,80	31,10	42,00	52,20	64,00	73,00	78,00	86,00	
9,52	11,13	15,09	19,05	23,83	27,79	31,75	35,71	14 x 10
7,80	9,27	12,70	15,09	18,26	21,44	25,40	28,57	
26,80	31,10	42,00	52,20	64,00	73,00	78,00	86,00	
9,52	11,13	15,09	19,05	23,83	27,79	31,75	35,71	14 x 8
7,03	8,18	10,31	12,70	15,09	18,26	20,62	23,01	
26,80	31,10	42,00	52,20	64,00	73,00	78,00	86,00	
	11,13		19,05		27,79		35,71	14 x 6
	7,11		10,97		14,27		18,26	
	31,10		52,20		73,00		86,00	
9,52	12,70	16,66	21,44	26,19	30,90	36,53	40,49	16 x 14
9,52	11,13	15,09	19,05	23,83	27,79	31,75	35,71	
33,10	43,80	57,00	72,20	83,00	97,00	112,00	121,00	
9,52	12,70	16,66	21,44	26,19	30,96	36,53	40,49	16 x 12
8,38	10,31	14,27	17,48	21,44	25,40	28,57	33,32	
33,10	43,80	57,00	72,20	83,00	97,00	112,00	121,00	
9,52	12,70	16,66	21,44	26,19	30,96	36,53	40,49	16 x 10
7,80	9,27	12,70	15,09	18,26	21,44	25,40	28,57	
33,10	43,80	57,00	72,20	83,00	97,00	112,00	121,00	
9,52	12,70	16,66	21,44	26,19	30,96	36,53	40,49	16 x 8
7,03	8,18	10,31	12,70	15,09	18,26	20,62	23,01	
33,10	43,80	57,00	72,20	83,00	97,00	112,00	121,00	

Weights are approximate.



réductions concentriques et excentriques

ASME B 16.9-1993

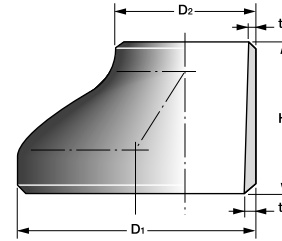
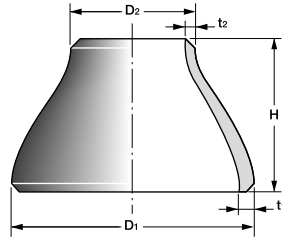

concentric and eccentric reducers

ASME B 16.9-1993

Diamètre Nominal Nominal Pipe Size (NPS)	Dia. extérieur au chanfrein Outside diameter at bevel	Longueur End-to-end length	STD	E.F. X.S.	X.E.F. X.X.S.	SCH 10	SCH 20
			t ₁ ép./W.T. mm		t ₂ ép./W.T. mm		masse/weight kg
Pouces/Inches	D – mm	H – mm					
18 x 16	457	381	9,52	12,70		6,35	7,92
	406		9,52	12,70		6,35	7,92
			40,00	53,00		34,00	33,30
18 x 14	457	381	9,52	12,70		6,35	7,92
	356		9,52	12,70		6,35	7,92
			40,00	53,00		34,00	33,30
18 x 12	457	381	9,52	12,70			7,92
	324		9,52	12,70			6,35
			40,00	53,00			33,30
18 x 10	457	381	9,52	12,70			7,92
	273		9,27	12,70			6,35
			40,00	53,00			33,30
20 x 18	508	508	9,52	12,70		6,35	9,52
	457		9,52	12,70		6,35	7,92
			59,00	79,00		50,00	58,00
20 x 16	508	508	9,52	12,70		6,35	9,52
	406		9,52	12,70		6,35	7,92
			59,00	79,00		50,00	58,00
20 x 14	508	508	9,52	12,70		6,35	9,52
	356		9,52	12,70		6,35	7,92
			59,00	79,00		50,00	58,00
20 x 12	508	508	9,52	12,70			9,52
	324		9,52	12,70			6,35
			59,00	79,00			58,00
22 x 20	559	508	9,52	12,70		6,35	9,52
	508		9,52	12,70		6,35	9,52
			65,00	87,00		57,00	61,00
22 x 18	559	508	9,52	12,70		6,35	9,52
	457		9,52	12,70		6,35	7,92
			65,00	87,00		57,00	61,00

Les masses indiquées sont approximatives.

SCH 30	SCH 40	SCH 60	SCH 80	SCH 100	SCH 120	SCH 140	SCH 160	Diamètre Nominal Nominal Pipe Size (NPS)
t ₁ ép./W.T. mm							Pouces/Inches	
t ₂ ép./W.T. mm								masse/weight kg
11,13	14,27	19,05	23,83	29,36	34,93	39,67	45,24	
9,52	12,70	16,66	21,44	26,19	30,96	36,53	40,49	
48,00	59,00	79,00	96,70	116,00	136,00	145,00	159,00	
11,13	14,27	19,05	23,83	29,36	34,93	39,67	45,24	18 x 14
9,52	11,13	15,09	19,05	23,83	27,79	31,75	35,71	
48,00	59,00	79,00	96,70	116,00	136,00	145,00	159,00	
11,13	14,27	19,05	23,83	29,36	34,93	39,67	45,24	18 x 12
8,38	10,31	14,27	17,48	21,44	25,40	28,57	33,32	
48,00	59,00	79,00	96,70	116,00	136,00	145,00	159,00	
11,13	14,27	19,05	23,83	29,36	34,93	39,67	45,24	18 x 10
7,80	9,27	12,70	15,09	18,26	21,44	25,40	28,57	
48,00	59,00	79,00	96,70	116,00	136,00	145,00	159,00	
12,70	15,09	20,62	26,18	32,54	38,10	44,45	50,01	20 x 18
11,13	14,27	19,05	23,83	29,36	34,93	39,67	45,24	
79,00	93,00	126,00	158,00	163,00	178,00	305,00	340,00	
12,70	15,09	20,62	26,18	32,54	38,10	44,45	50,01	20 x 16
9,52	12,70	16,66	21,44	26,19	30,96	36,53	40,49	
79,00	93,00	126,00	158,00	163,00	178,00	305,00	340,00	
12,70	15,09	20,62	26,18	32,54	38,10	44,45	50,01	20 x 14
9,52	11,13	15,09	19,05	23,83	27,79	31,75	35,71	
79,00	93,00	126,00	158,00	163,00	178,00	305,00	340,00	
12,70	15,09	20,62	26,18	32,54	38,10	44,45	50,01	20 x 12
8,38	10,31	14,27	17,48	21,44	25,40	28,57	33,32	
79,00	93,00	126,00	158,00	163,00	178,00	305,00	340,00	
12,70		22,22	28,58	34,92	41,27	47,62	53,97	22 x 20
12,70		20,62	26,18	32,54	38,10	44,45	50,01	
92,00		150,00	188,00	201,00	233,00	415,00	460,00	
12,70		22,22	28,58	34,92	41,27	47,62	53,97	22 x 18
11,13		19,05	23,83	29,36	34,93	39,67	45,24	
92,00		150,00	188,00	201,00	233,00	415,00	460,00	

Weights are approximate.

réductions concentriques et excentriques

ASME B 16.9-1993

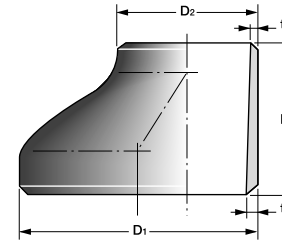
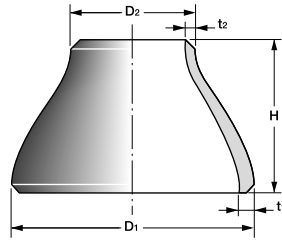

concentric and eccentric reducers

ASME B 16.9-1993

Diamètre Nominal Nominal Pipe Size (NPS)	Dia. extérieur au chanfrein Outside diameter at bevel	Longueur End-to-end length	STD	E.F. X.S.	X.E.F. X.X.S.	SCH 10	SCH 20
			t ₁ ép./W.T. mm		t ₂ ép./W.T. mm		masse/weight kg
Pouces/Inches	D – mm	H – mm					
22 x 16	559	508	9,52	12,70		6,35	9,52
	406		9,52	12,70		6,35	7,92
			65,00	87,00		57,00	61,00
22 x 14	559	508	9,52	12,70		6,35	9,52
	356		9,52	12,70		6,35	7,92
			65,00	87,00		57,00	61,00
24 x 22	610	508	9,52	12,70		6,35	9,52
	559		9,52	12,70		6,35	9,52
			72,00	95,00		63,00	72,00
24 x 20	610	508	9,52	12,70		6,35	Voir STD
	508		9,52	12,70		6,35	Refer to
			72,00	95,00		63,00	STD
24 x 18	610	508	9,52	12,70		6,35	9,52
	457		9,52	12,70		6,35	7,92
			72,00	95,00		63,00	72,00
24 x 16	610	508	9,52	12,70		6,35	9,52
	406		9,52	12,70		6,35	7,92
			72,00	95,00		63,00	72,00
26 x 24	660	610	9,52	12,70		7,92	12,70
	610		9,52	12,70		6,35	9,52
			91,00	125,00		75,00	123,00
26 x 22	660	610	9,52	12,70		7,92	12,70
	559		9,52	12,70		6,35	9,52
			91,00	125,00		75,00	123,00
26 x 20	660	610	9,52	12,70		7,92	12,70
	508		9,52	12,70		6,35	9,52
			91,00	115,00		75,00	123,00
26 x 18	660	610	9,52	12,70		7,92	12,70
	457		9,52	12,70		6,35	9,52
			91,00	115,00		75,00	123,00

Les masses indiquées sont approximatives.

SCH 30	SCH 40	SCH 60	SCH 80	SCH 100	SCH 120	SCH 140	SCH 160	Diamètre Nominal Nominal Pipe Size (NPS)
t ₁ ép./W.T. mm		t ₂ ép./W.T. mm		masse/weight kg				
								Pouces/Inches
12,70		22,22	28,58	34,92	41,27	47,62	53,97	22 x 16
9,52		16,66	21,44	26,19	30,96	36,53	40,49	
92,00		150,00	188,00	201,00	233,00	415,00	460,00	
12,70		22,22	28,58	34,92	41,27	47,62	53,97	22 x 14
9,52		15,09	19,05	23,83	27,79	31,75	35,71	
92,00		150,00	188,00	201,00	233,00	415,00	460,00	
14,27		24,61	30,96	38,89	46,02	52,37	59,54	24 x 22
12,70		22,22	28,58	34,92	41,27	47,62	53,97	
107,00		180,00	228,00	241,00	295,00	540,00	610,00	
14,27	17,48	24,61	30,96	38,89	46,02	52,37	59,54	24 x 20
12,70	15,09	20,62	26,18	32,54	38,10	44,45	50,01	
107,00	129,00	180,00	228,00	241,00	295,00	540,00	610,00	
14,27	17,48	24,61	30,96	38,89	46,02	52,37	59,54	24 x 18
11,13	14,27	19,05	23,83	29,36	34,93	39,67	45,24	
107,00	129,00	180,00	228,00	241,00	295,00	540,00	610,00	
14,27	17,48	24,61	30,96	38,89	46,02	52,37	59,54	24 x 16
9,52	12,70	16,66	21,44	26,19	30,96	36,53	40,49	
107,00	129,00	180,00	228,00	241,00	295,00	540,00	610,00	
								26 x 24
								26 x 22
								26 x 20
								26 x 18

Weights are approximate.



réductions concentriques et excentriques

ASME B 16.9-1993

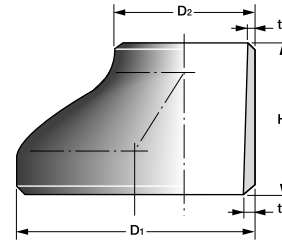
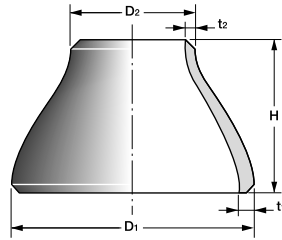

concentric and eccentric reducers

ASME B 16.9-1993

Diamètre Nominal Nominal Pipe Size (NPS)	Dia. extérieur au chanfrein Outside diameter at bevel	Longueur End to end length	STD	E.F. X.S.	X.E.F. X.X.S.	SCH 10	SCH 20	
			t ₁ ép./W.T. mm		t ₂ ép./W.T. mm		masse/weight kg	
Pouces/Inches	D - mm	H - mm						
28 x 26	711	610	9,52	12,70		7,92	12,70	
	660		9,52	12,70		7,92	12,70	
			95,00	132,00		79,00	131,00	
28 x 24	711	610	9,52	12,70		7,92	12,70	
	610		9,52	12,70		6,35	9,52	
			95,00	132,00		79,00	131,00	
28 x 20	711	610	9,52	12,70		7,92	12,70	
	508		9,52	12,70		6,35	9,52	
			95,00	132,00		79,00	131,00	
28 x 18	711	610	9,52	12,70		7,92	12,70	
	457		9,52	12,70		6,35	7,92	
			95,00	132,00		79,00	131,00	
30 x 28	762	610	9,52	12,70		7,92	12,70	
	711		9,52	12,70		7,92	12,70	
			100,00	143,00		83,00	142,00	
30 x 26	762	610	9,52	12,70		7,92	12,70	
	660		9,52	12,70		7,92	12,70	
			100,00	143,00		83,00	142,00	
30 x 24	762	610	9,52	12,70		7,92	12,70	
	610		9,52	12,70		6,35	9,52	
			100,00	143,00		83,00	142,00	
30 x 20	762	610	9,52	12,70		7,92	12,70	
	508		9,52	12,70		6,35	9,52	
			100,00	143,00		83,00	142,00	
32 x 30	813	610	9,52	12,70		7,92	12,70	
	762		9,52	12,70		7,92	12,70	
			115,00	150,00		96,00	150,00	
32 x 28	813	610	9,52	12,70		7,92	12,70	
	711		9,52	12,70		7,92	12,70	
			115,00	150,00		96,00	150,00	
32 x 26	813	610	9,52	12,70		7,92	12,70	
	660		9,52	12,70		7,92	12,70	
			115,00	150,00		96,00	150,00	
32 x 24	813	610	9,52	12,70		7,92	12,70	
	610		9,52	12,70		6,35	9,52	
			115,00	150,00		96,00	150,00	

Les masses indiquées sont approximatives.

SCH 30	SCH 40	SCH 60	SCH 80	SCH 100	SCH 120	SCH 140	SCH 160	Diamètre Nominal Nominal Pipe Size (NPS)
t ₁ ép./W.T. mm		t ₂ ép./W.T. mm		masse/weight kg			Pouces/Inches	
								28 x 26
								28 x 24
								28 x 20
								28 x 18
								30 x 28
								30 x 26
								30 x 24
								30 x 20
								32 x 30
								32 x 28
								32 x 26
								32 x 24

Weights are approximate.



réductions concentriques et excentriques

ASME B 16.9-1993

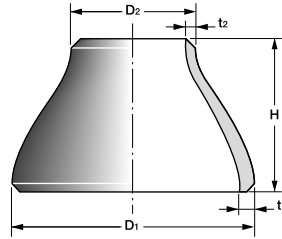

Diamètre Nominal Nominal Pipe Size (NPS)	Dia. extérieur au chanfrein Outside diameter at bevel	Longueur End-to-end length	STD	E.F. X.S.	SCH 10	SCH 20	SCH 30
			t ₁ ép./W.T. mm				
Pouces/Inches	D – mm	H – mm	t ₂ ép./W.T. mm				
masse/weight kg							
34 x 32	864	610	9,52	12,70	7,92	12,70	15,88
	813		9,52	12,70	7,92	12,70	15,88
			123,00	162,00	112,00	157,00	202,00
34 x 30	864	610	9,52	12,70	7,92	12,70	15,88
	762		9,52	12,70	7,92	12,70	15,88
			123,00	162,00	112,00	157,00	202,00
34 x 28	864	610	9,52	12,70	7,92	12,70	15,88
	711		9,52	12,70	7,92	12,70	15,88
			123,00	162,00	112,00	157,00	202,00
34 x 24	864	610	9,52	12,70	7,92	12,70	15,88
	610		9,52	12,70	6,35	9,52	14,27
			123,00	162,00	112,00	157,00	202,00
36 x 34	914	610	9,52	12,70	7,92	12,70	15,88
	864		9,52	12,70	7,92	12,70	15,88
			129,00	172,00	123,00	172,00	221,00
36 x 32	914	610	9,52	12,70	7,92	12,70	15,88
	813		9,52	12,70	7,92	12,70	15,88
			129,00	172,00	123,00	172,00	221,00
36 x 30	914	610	9,52	12,70	7,92	12,70	15,88
	762		9,52	12,70	7,92	12,70	15,88
			129,00	172,00	123,00	172,00	221,00
36 x 26	914	610	9,52	12,70	7,92	12,70	
	660		9,52	12,70	7,92	12,70	
			129,00	172,00	123,00	172,00	
36 x 24	914	610	9,52	12,70	7,92	12,70	15,88
	610		9,52	12,70	6,35	9,52	14,27
			129,00	172,00	123,00	172,00	221,00
38 x 36	965	610	9,52	12,70			
	914		9,52	12,70			
			136,00	186,00			
38 x 34	965	610	9,52	12,70			
	864		9,52	12,70			
			136,00	186,00			

Les masses indiquées sont approximatives.

concentric and eccentric reducers

ASME B 16.9-1993

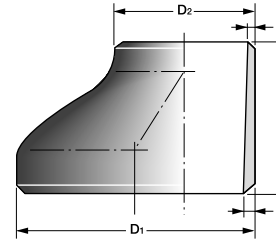

Diamètre Nominal Nominal Pipe Size (NPS)	Dia. extérieur au chanfrein Outside diameter at bevel	Longueur End-to-end length	STD	E.F. X.S.
			t ₁ ép./W.T. mm	
Pouces/Inches	D – mm	H – mm	t ₂ ép./W.T. mm	
masse/weight kg				
38 x 32	965	610	9,52	12,70
	813		9,52	12,70
			136,00	186,00
38 x 30	965	610	9,52	12,70
	762		9,52	12,70
			136,00	186,00
38 x 28	965	610	9,52	12,70
	711		9,52	12,70
			136,00	186,00
38 x 26	965	610	9,52	12,70
	660		9,52	12,70
			136,00	186,00
40 x 38	1016	610	9,52	12,70
	965		9,52	12,70
			143,00	193,00
40 x 36	1016	610	9,52	12,70
	914		9,52	12,70
			143,00	193,00
40 x 34	1016	610	9,52	12,70
	864		9,52	12,70
			143,00	193,00
40 x 32	1016	610	9,52	12,70
	813		9,52	12,70
			143,00	193,00
40 x 30	1016	610	9,52	12,70
	762		9,52	12,70
			143,00	193,00
42 x 40	1067	610	9,52	12,70
	1016		9,52	12,70
			152,00	201,00
42 x 38	1067	610	9,52	12,70
	965		9,52	12,70
			152,00	201,00

Weights are approximate.



réductions concentriques et excentriques

ASME B 16.9-1993

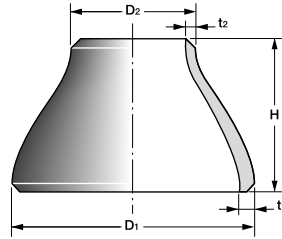

Diamètre Nominal Nominal Pipe Size (NPS)	Dia. extérieur au chanfrein Outside diameter at bevel	Longueur End-to-end length	STD		E.F. X.S.	
			t ₁ ép./W.T.	mm	t ₂ ép./W.T.	mm
Pouces/Inches	D – mm	H – mm	masse/weight kg			
42 x 36	1067	610	9,52	12,70		
	914		9,52	12,70		
			152,00	201,00		
42 x 34	1067	610	9,52	12,70		
	864		9,52	12,70		
			152,00	201,00		
42 x 32	1067	610	9,52	12,70		
	813		9,52	12,70		
			152,00	201,00		
42 x 30	1067	610	9,52	12,70		
	762		9,52	12,70		
			152,00	201,00		
44 x 42	1118	610	9,52	12,70		
	1067		9,52	12,70		
			159,00	211,00		
44 x 40	1118	610	9,52	12,70		
	1016		9,52	12,70		
			159,00	211,00		
44 x 38	1118	610	9,52	12,70		
	965		9,52	12,70		
			159,00	211,00		
44 x 36	1118	610	9,52	12,70		
	914		9,52	12,70		
			159,00	211,00		
46 x 44	1168	711	9,52	12,70		
	1118		9,52	12,70		
			170,00	225,00		
46 x 42	1168	711	9,52	12,70		
	1067		9,52	12,70		
			170,00	225,00		

Les masses indiquées sont approximatives.

concentric and eccentric reducers

ASME B 16.9-1993

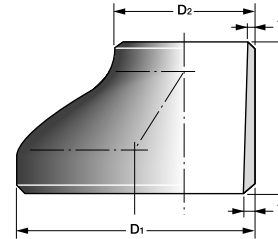

Diamètre Nominal Nominal Pipe Size (NPS)	Dia. extérieur au chanfrein Outside diameter at bevel	Longueur End-to-end length	STD		E.F. X.S.	
			t ₁ ép./W.T.	mm	t ₂ ép./W.T.	mm
Pouces/Inches	D – mm	H – mm	masse/weight kg			
46 x 40	1168	711	9,52	12,70		
	1016		9,52	12,70		
			170,00	225,00		
46 x 38	1168	711	9,52	12,70		
	965		9,52	12,70		
			170,00	225,00		
48 x 46	1219	711	9,52	12,70		
	1168		9,52	12,70		
			181,00	238,00		
48 x 44	1219	711	9,52	12,70		
	1118		9,52	12,70		
			181,00	238,00		
48 x 42	1219	711	9,52	12,70		
	1067		9,52	12,70		
			181,00	238,00		
48 x 40	1219	711	9,52	12,70		
	1016		9,52	12,70		
			181,00	238,00		

Weights are approximate.





RACCORDS
EN ACIERS INOXYDABLES

STAINLESS STEEL FITTINGS



coudes – tés – réductions – caps – collets

Diamètre nominal NPS	Tous raccords		Coudes 90°/45° Tés	Réductions, Collets	Coudes 180°			Caps	Collets pour brides tournantes	
	Dia. (1) extérieur ou chanfrein D	Épaisseur t	Dimension centre-à- extrémité	Longueur hors tout	Dimension centre-à- centre	Dimension hauteur hors tout	Alignement des extrémités	Longueur hors tout	Rayon (2)	Dia. extérieur du collet
			A-B-C-M	F-H	O	K	U	E	A	G
1/2 – 3 1/2	± 0,8	Pas plus petite que 87,5 % de l'épaisseur nominale	± 1,6	± 1,6	± 6,35	± 6,35	± 0,8	± 3,0	+ 0 - 0,8	+ 0 - 0,8
4	± 0,8		± 1,6	± 1,6	± 6,35	± 6,35	± 0,8	± 3,0	+ 0 - 1,6	+ 0 - 0,8
5 – 8	+ 1,6 - 0,8		± 1,6	± 1,6	± 6,35	± 6,35	± 0,8	± 6,35	+ 0 - 1,6	+ 0 - 0,8
10 – 18	+ 2,3 - 0,8		± 2,3	± 2,3	± 9,65	± 6,35	± 1,6	± 6,35	+ 0 - 1,6	+ 0 - 1,6
20 – 24	+ 3,0 - 0,8		± 2,3	± 2,3	± 9,65	± 6,35	± 1,6	± 6,35	+ 0 - 1,6	+ 0 - 1,6

Dimensions en mm (sauf NPS)

Note : (1) L'ovalisation est la somme des valeurs absolues des tolérances plus ou moins.

(2) Le rayon B est un maxi (voir pages 2-126 et 2-127)

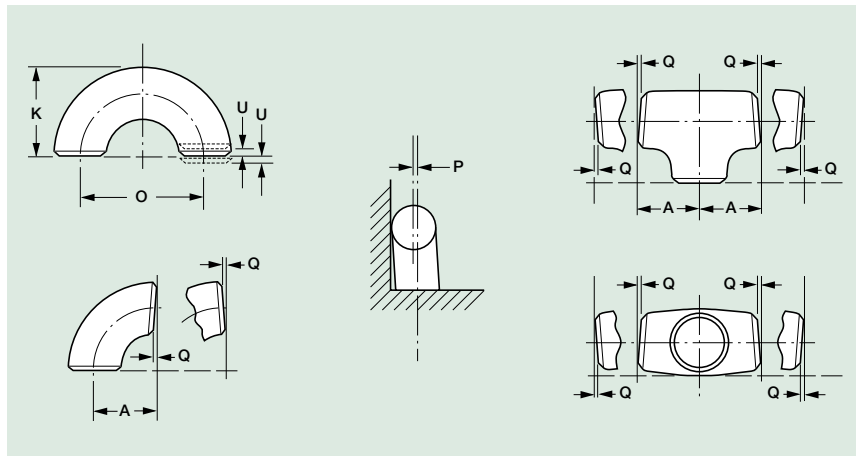

elbows – tees – reducers – caps – stub ends

Nominal Pipe Size NPS	All fittings		90°/45° Elbows, Tees	Reducers, Stub ends	180° returns			Caps	Lap-joint Stub ends	
	Outside (1) diameter at welding end D	Wall thickness t	Center-to- end dimension	Overall length	Center-to- center dimension	Back-to- face dimension	Alignment of ends	Overall length	Fillet (2) radius of lap	Outside diameter of lap
			A-B-C-M	F-H	O	K	U	E	A	G
1/2 – 3 1/2	± 0.03	Not less than 87.5 % of nominal thickness	± 0.06	± 0.06	± 0.25	± 0.25	± 0.03	± 0.12	+ 0 - 0.03	+ 0 - 0.03
4	± 0.03		± 0.06	± 0.06	± 0.25	± 0.25	± 0.03	± 0.12	+ 0 - 0.06	+ 0 - 0.03
5 – 8	+ 0.06 - 0.03		± 0.06	± 0.06	± 0.25	± 0.25	± 0.03	± 0.25	+ 0 - 0.06	+ 0 - 0.03
10 – 18	+ 0.09 - 0.03		± 0.09	± 0.09	± 0.38	± 0.25	± 0.06	± 0.25	+ 0 - 0.06	+ 0 - 0.06
20 – 24	+ 0.12 - 0.03		± 0.09	± 0.09	± 0.38	± 0.25	± 0.06	± 0.25	+ 0 - 0.06	+ 0 - 0.06

Dimensions in inches

Note : (1) Out of roundness is the vector sum of plus and minus tolerance.

(2) Fillet B radius is maximum (see pages 2-126 and 2-127).

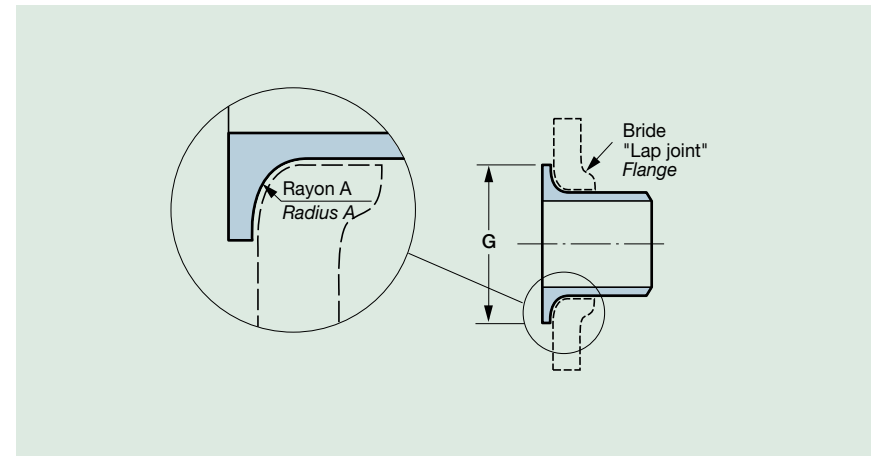

spécifications ASTM

ACIERS INOXYDABLES AUSTÉNITIQUES

ASTM standards

AUSTENITIC STAINLESS STEELS

Les raccords en acier inoxydable répondent, en ce qui concerne la matière, aux exigences de l'ASTM.

For steel, stainless steel fittings are in strict accordance with ASTM requirements.

ASTM A 403 / A 403 M - 95		Nuance / Grade (1) (2)				
		WP 304 CR 304	WP 304 L CR 304 L	WP 316 CR 316	WP 316 L CR 316 L	WP 321 CR 321
Composition chimique %	C maxi	0,08	0,035 (d)	0,08	0,035 (d)	0,08
	Mn maxi	2,00	2,00	2,00	2,00	2,00
	P maxi	0,045	0,045	0,045	0,045	0,045
	S maxi	0,030	0,030	0,030	0,030	0,030
Chemical requirements %	Si maxi	1,00	1,00	1,00	1,00	1,00
	Ni	8,00 / 11,0	8,00 / 13,0	10,0 / 14,0	10,0 / 16,0 (e)	9,00 / 13,0
	Cr	18,0 / 20,0	18,0 / 20,0	16,0 / 18,0	16,0 / 18,0	17,0 / 20,0
	Nb	-	-	2,0 / 3,0	2,0 / 3,0	-
	Ti	-	-	-	-	(f)

(d) Une teneur maxi en carbone de 0,040 % est nécessaire pour les petits diamètres extérieurs (inférieurs à 12,7 mm) ou les faibles épaisseurs (inférieures à 1,24 mm).

(e) Sur les tubes forés, le nickel peut être de 11,0 - 16,0 %.

(f) Ti : 5 x % C minimum - 0,70 % maximum

(d) A carbon maximum of 0.040 % is necessary for small outside diameters (less than 0.500 in) or thin walls (less than 0.049 in).

(e) On pierced tubing, the nickel may be 11.0 - 16.0 %.

(f) Ti : 5 x % C minimum - 0.70 % maximum

Caractéristiques mécaniques Mechanical requirements	Limite élastique minimum Minimum yield strength		MPa	205	170	205	170	205
	ksi	ksi						
Résistance minimum Minimum tensile strength	MPa		ksi	515	485	515	485	515
	ksi							
Allongement minimum % sur 4D (3) Elongation minimum % in 4D (3)			Long. 28 - Transv. 20					

(1) Les nuances WP répondent aux conditions de ANSI B 16-9 et B 16-28 ; la nuance CR répond aux conditions de MSS-SP 43

(2) La désignation de la nuance WP sera suivie des symboles suivant : «S» pour les raccords sans soudure, «W», «WX» ou «WU» pour les raccords comportant des soudures

(3) Pour éprouvette cylindrique standard ou éprouvette proportionnelle réduite ou éprouvette sous forme de bande découpée dans le tube.

Note : Suivant ASTM A 403, les raccords comportant des soudures contrôlées aux ultrasons au lieu d'être radiographiées seront marquées "U" après l'identification de la coulée.

(1) Classes WP are manufactured to the requirements of ANSI B 16-9 and B 16-28 ; class CR are those manufactured to the requirements of MSS-SP 43

(2) The WP class designation shall be supplemented by following symbols :

«S» for seamless fittings,
«W», «WX» or «WU» for fittings of welded construction

(3) Standard round specimen or small proportional specimen, or strip-type specimen.

Note : According to ASTM A 403, fittings containing welds which have been ultrasonically examined in place of radiography shall be marked "U" after heat identification.



coudes long rayon à 45°

ASME B 16-9 – 1993
MSS-SP 43-1991

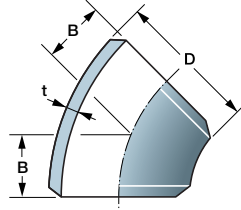

45° long radius elbows

ASME B 16-9 – 1993
MSS-SP 43-1991

Diamètre Nominal Nominal Pipe Size (NPS)	Dia. extérieur au chanfrein Outside diameter at bevel	Centre-à-extrémité Center-to-end	SCH 5S	SCH 10S	SCH 40S	SCH 80S
			t ép./W.T. mm masse/weight kg			
Pouces/Inches	D – mm	B – mm				
1/2	21	16	1,65	2,11	2,77	3,73
			0,02	0,03	0,04	0,05
3/4	27	19 (1)	1,65	2,11	2,87	3,91
			0,03	0,03	0,04	0,05
1	33	22	1,65	2,77	3,38	4,55
			0,05	0,09	0,12	0,15
1 1/4	42	25	1,65	2,77	3,56	4,85
			0,09	0,12	0,15	0,25
1 1/2	48	29	1,65	2,77	3,68	5,08
			0,11	0,17	0,22	0,30
2	60	35	1,65	2,77	3,91	5,54
			0,14	0,25	0,35	0,50
2 1/2	73	44	2,11	3,05	5,16	7,01
			0,34	0,48	0,75	1,00
3	89	51	2,11	3,05	5,49	7,62
			0,48	0,62	1,05	1,50
3 1/2	102	57	2,11	3,05	5,74	8,08
			0,55	0,76	1,45	2,00
4	114	64	2,11	3,05	6,02	8,56
			0,75	1,10	2,10	3,10

Les masses indiquées sont approximatives

(1) La dimension peut être 11 mm suivant option du fabricant

(2) Ces dimensions ne sont pas reprises dans ASME B 36-19 M

Diamètre Nominal Nominal Pipe Size (NPS)	Dia. extérieur au chanfrein Outside diameter at bevel	Centre-à-extrémité Center-to-end	SCH 5S	SCH 10S	SCH 40S	SCH 80S
			t ép./W.T. mm masse/weight kg			
Pouces/Inches	D – mm	B – mm				
5	141	79	2,77	3,40	6,55	9,53
			1,50	1,80	3,40	4,80
6	168	95	2,77	3,40	7,11	10,97
			2,25	2,75	5,40	8,20
8	219	127	2,77	3,76	8,18	12,70
			4,00	5,30	10,70	16,50
10	273	159	3,40	4,19	9,27	12,70
			7,25	9,80	19,30	26,00
12	324	190	3,96	4,57	9,53	12,70
			11,60	13,60	29,70	40,00
14	356	222	3,96	4,78	9,53	
			15,40	18,10	35,40	(2)
16	406	254	4,19	4,78	9,53	
			22,60	23,80	46,20	(2)
18	457	286	4,19	4,78	9,53	
			28,40	30,0	59,80	(2)
20	508	318	4,78	5,54	9,53	
			37,40	50,00	74,00	(2)
22	559	343	4,78	5,54	9,53	
						(2)
24	610	381	5,54	6,35	9,53	
			63,50	71,00	105,00	(2)

Weights are approximate

(1) The dimension may be 11 mm at the manufacturer's option

(2) Those do not conform to ASME B 36-19 M



coudes long rayon à 90°

ASME B 16-9 – 1993
MSS-SP 43-1991

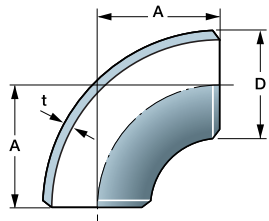

90° long radius elbows

ASME B 16-9 – 1993
MSS-SP 43-1991

Diamètre Nominal Nominal Pipe Size (NPS)	Dia. extérieur au chanfrein Outside diameter at bevel	Centre-à-extrémité Center-to-end	SCH 5S	SCH 10S	SCH 40S	SCH 80S
			t ép./W.T. mm masse/weight kg			
Pouces/Inches	D – mm	A – mm				
1/2	21	38	1,65	2,11	2,77	3,73
			0,06	0,06	0,08	0,10
3/4	27	38 (1)	1,65	2,11	2,87	3,91
			0,06	0,07	0,09	0,12
1	33	38	1,65	2,77	3,38	4,55
			0,09	0,15	0,16	0,22
1 1/4	42	48	1,65	2,77	3,56	4,85
			0,14	0,25	0,25	0,40
1 1/2	48	57	1,65	2,77	3,68	5,08
			0,17	0,30	0,40	0,50
2	60	76	1,65	2,77	3,91	5,54
			0,30	0,50	0,70	0,90
2 1/2	73	95	2,11	3,05	5,16	7,01
			0,70	0,85	1,40	1,80
3	89	114	2,11	3,05	5,49	7,62
			0,90	1,20	2,20	3,00
3 1/2	102	133	2,11	3,05	5,74	8,08
			1,20	1,70	2,90	4,00
4	114	152	2,11	3,05	6,02	8,56
			1,50	2,20	4,20	6,20

Les masses indiquées sont approximatives.
(1) La dimension peut être 29 mm suivant option du fabricant.

Diamètre Nominal Nominal Pipe Size (NPS)	Dia. extérieur au chanfrein Outside diameter at bevel	Centre-à-extrémité Center-to-end	SCH 5S	SCH 10S	SCH 40S	SCH 80S
			t ép./W.T. mm masse/weight kg			
Pouces/Inches	D – mm	A – mm				
5	141	190	2,77	3,40	6,55	9,53
			3,00	3,60	6,90	9,60
6	168	229	2,77	3,40	7,11	10,97
			4,50	5,40	11,00	16,30
8	219	305	2,77	3,76	8,18	12,70
			7,80	10,60	21,50	33,10
10	273	381	3,40	4,19	9,27	12,70
			14,50	19,50	38,50	52,00
12	324	457	3,96	4,57	9,53	12,70
			23,10	27,50	60,00	80,00
14	356	533	3,96	4,78	9,53	
			30,80	36,00	70,00	(2)
16	406	610	4,19	4,78	9,53	
			45,30	47,50	92,00	(2)
18	457	686	4,19	4,78	9,53	
			56,60	60,00	122,00	(2)
20	508	762	4,78	5,54	9,53	
			75,00	100,00	150,00	(2)
22	559	838	4,78	5,54	9,53	
						(2)
24	610	914	5,54	6,35	9,53	
			130,00	140,00	210,00	(2)

Weights are approximate.
(1) The dimension may be 29 mm at the manufacturer's option
(2) Those do not conform to ASME B 36-19 M



coudes long rayon à 180°

ASME B 16-9 – 1993
MSS-SP 43-1991

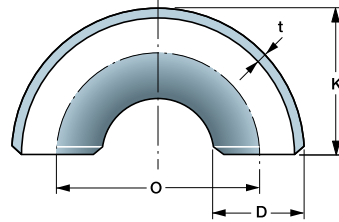

long radius returns

ASME B 16-9 – 1993
MSS-SP 43-1991

Diamètre Nominal Nominal Pipe Size (NPS)	Dia. extérieur au chanfrein Outside diameter at bevel	Entraxe Center-to-center	Hauteur Back-to-face	SCH 5S	SCH 10S	SCH 40S	SCH 80S
				t ép./W.T. mm masse/weight kg			
Pouces/Inches	D – mm	O – mm	K – mm				
1/2	21	76	48	1,65	2,11	2,77	3,73
				0,10	0,12	0,16	0,20
3/4	27	76 (1)	51 (1)	1,65	2,11	2,87	3,91
				0,14	0,19	0,23	0,32
1	33	76	56	1,65	2,77	3,38	4,55
				0,24	0,34	0,35	0,65
1 1/4	42	95	70	1,65	2,77	3,56	4,85
				0,45	0,57	0,75	1,10
1 1/2	48	114	83	1,65	2,77	3,68	5,08
				0,60	0,80	1,05	1,40
2	60	152	106	1,65	2,77	3,91	5,54
				0,95	1,40	2,00	2,80
2 1/2	73	191	132	2,11	3,05	5,16	7,01
				1,60	2,70	3,50	4,40
3	89	229	159	2,11	3,05	5,49	7,62
				2,40	4,50	5,80	7,80
3 1/2	102	267	184	2,11	3,05	5,74	8,08
				3,00	4,80	7,10	10,00
4	114	305	210	2,11	3,05	6,02	8,56
				5,40	6,20	11,10	15,50

Les masses indiquées sont approximatives

(1) Les dimensions O et K pour NPS 3/4" peuvent être respectivement 57 et 43 mm à l'option du fabricant

(2) Ces dimensions ne sont pas reprises dans ASME B 36-19 M

(3) NPS 22" uniquement pour ASME B16-9

Diamètre Nominal Nominal Pipe Size (NPS)	Dia. extérieur au chanfrein Outside diameter at bevel	Entraxe Center-to-center	Hauteur Back-to-face	SCH 5S	SCH 10S	SCH 40S	SCH 80S
				t ép./W.T. mm masse/weight kg			
Pouces/Inches	D – mm	O – mm	K – mm				
5	141	381	262	2,77	3,40	6,55	9,53
				5,90	7,30	14,10	19,50
6	168	457	313	2,77	3,40	7,11	10,97
				9,10	10,90	21,70	32,50
8	219	610	414	2,77	3,76	8,18	12,70
				15,90	21,50	43,00	66,00
10	273	762	518	3,40	4,19	9,27	12,70
				29,00	39,00	77,00	103,00
12	324	914	619	3,96	4,57	9,53	12,70
				46,20	54,50	120,00	160,00
14	356	1067	711	3,96	4,78	9,53	
				62,00	72,50	140,00	(2)
16	406	1219	813	4,19	4,78	9,53	
				91,00	96,00	185,00	(2)
18	457	1372	914	4,19	4,78	9,53	
				113,00	120,00	245,00	(2)
20	508	1524	1016	4,78	5,54	9,53	
				150,00	200,00	300,00	(2)
22 (3)	559	1676	1118	4,78	5,54		
24	610	1829	1219	5,54	6,35	9,53	
				255,00	280,00	420,00	(2)

Weights are approximate

(1) O and K dimensions for size NPS 3/4" may be O = 57 mm and K = 43 mm at the manufacturer's option

(2) Those do not conform to ASME B 36-19 M

(3) NPS 22" only for ASME B 16-9



coudes court rayon à 90°

ASME B 16-28 – 1994

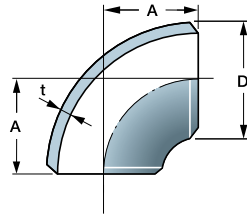

90° short radius elbows

ASME B 16-28 – 1994

Diamètre Nominal Nominal Pipe Size (NPS)	Dia. extérieur au chanfrein Outside diameter at bevel	Centre-à-extrémité Center-to-end	SCH 5S	SCH 10S	SCH 40S	SCH 80S
			t ép./W.T. mm masse/weight kg			
Pouces/Inches	D – mm	A – mm				
1	33	25	1,65	2,77	3,38	4,55
			0,08	0,10	0,12	0,18
1 1/4	42	32	1,65	2,77	3,56	4,85
			0,14	0,17	0,20	0,30
1 1/2	48	38	1,65	2,77	3,68	5,08
			0,19	0,22	0,30	0,40
2	60	51	1,65	2,77	3,91	5,54
			0,30	0,37	0,50	0,70
2 1/2	73	64	2,11	3,05	5,16	7,01
			0,60	0,75	1,05	1,30
3	89	76	2,11	3,05	5,49	7,62
			0,80	1,00	1,50	1,90
3 1/2	102	89	2,11	3,05	5,74	8,08
			1,05	1,40	2,05	2,40
4	114	102	2,11	3,05	6,02	8,56
			1,40	1,70	3,10	4,10
5	141	127	2,77	3,40	6,55	9,53
			2,25	2,80	5,30	7,30
6	168	152	2,77	3,40	7,11	10,97
			3,50	4,20	7,90	11,80

Les masses indiquées sont approximatives.

(2) Ces dimensions ne sont pas reprises dans ASME B 36-19 M

Diamètre Nominal Nominal Pipe Size (NPS)	Dia. extérieur au chanfrein Outside diameter at bevel	Centre-à-extrémité Center-to-end	SCH 5S	SCH 10S	SCH 40S	SCH 80S
			t ép./W.T. mm masse/weight kg			
Pouces/Inches	D – mm	A – mm				
8	219	203	2,77	3,76	8,18	12,70
			7,00	8,00	17,00	25,00
10	273	254	3,40	4,19	9,27	12,70
			12,40	15,90	28,50	45,00
12	324	305	3,96	4,57	9,53	12,70
			15,90	18,10	36,00	57,00
14	356	356	3,96	4,78	9,53	
			20,00	23,50	46,00	
16	406	406	4,19	4,78	9,53	
			29,50	31,00	60,00	
18	457	457	4,19	4,78	9,53	
			36,70	39,50	79,00	(2)
20	508	508	4,78	5,54	9,53	
			49,00	65,00	97,00	(2)
22	559	559	4,78	5,54		
24	610	610	5,54	6,35	9,53	
			83,00	92,00	137,00	(2)

Weights are approximate

(2) Those do not conform to ASME B 36-19 M



coudes court rayon à 180°

ASME B 16-28 – 1994

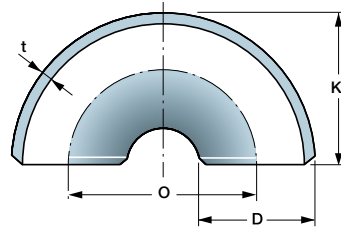

180° short radius returns

ASME B 16-28 – 1994

Diamètre Nominal Nominal Pipe Size (NPS)	Dia. extérieur au chanfrein Outside diameter at bevel	Entraxe Center-to- center	Hauteur Back-to- face	SCH 5S	SCH 10S	SCH 40S	SCH 80S
				† ép./W.T. mm masse/weight kg			
Pouces/Inches	D – mm	O – mm	K – mm				
1	33	51	41	1,65	2,77	3,38	4,55
				0,16	0,20	0,24	0,35
1 1/4	42	64	52	1,65	2,77	3,56	4,85
				0,30	0,35	0,40	0,60
1 1/2	48	76	62	1,65	2,77	3,68	5,08
				0,40	0,45	0,60	0,80
2	60	102	81	1,65	2,77	3,91	5,54
				0,55	0,75	1,05	1,40
2 1/2	73	127	100	2,11	3,05	5,16	7,01
				1,15	1,25	2,05	2,60
3	89	152	121	2,11	3,05	5,49	7,62
				1,60	2,00	3,00	3,80
3 1/2	102	178	140	2,11	3,05	5,74	8,08
				2,15	2,75	4,10	4,80
4	114	203	159	2,11	3,05	6,02	8,56
				2,80	3,50	6,25	8,20
5	141	254	197	2,77	3,40	6,55	9,53
				4,50	5,60	10,50	15,00
6	168	305	237	2,77	3,40	7,11	10,97
				7,00	8,30	16,00	24,00

Les masses indiquées sont approximatives.

(2) Ces dimensions ne sont pas reprises dans ASME B 36-19 M

Diamètre Nominal Nominal Pipe Size (NPS)	Dia. extérieur au chanfrein Outside diameter at bevel	Entraxe Center-to- center	Hauteur Back-to- face	SCH 5S	SCH 10S	SCH 40S	SCH 80S
				† ép./W.T. mm masse/weight kg			
Pouces/Inches	D – mm	O – mm	K – mm				
8	219	406	313	2,77	3,76	8,18	12,70
				14,00	16,00	34,00	50,00
10	273	508	391	3,40	4,19	9,27	12,70
				25,00	32,00	57,00	90,00
12	324	610	467	3,96	4,57	9,53	12,70
				32,00	36,00	73,00	113,00
14	356	711	533	3,96	4,78	9,53	
				40,00	47,00	92,00	
16	406	813	610	4,19	4,78	9,53	
				60,00	62,00	120,00	
18	457	914	686	4,19	4,78	9,53	
				74,00	78,00	160,00	(2)
20	508	1016	762	4,78	5,54	9,53	
				97,00	130,00	195,00	(2)
22	559	1118	838	4,78	5,54		
24	610	1219	914	5,54	6,35	9,53	
				165,00	185,00	275,00	(2)

Weights are approximate

(2) Those do not conform to ASME B 36-19 M



tés égaux

ASME B 16-9 – 1993
MSS-SP 43-1991

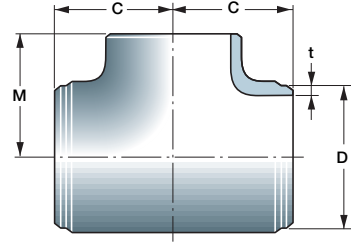

straight tees

ASME B 16-9 – 1993
MSS-SP 43-1991

Diamètre Nominal Nominal Pipe Size (NPS)	Dia. extérieur au chanfrein Outside diameter at bevel	Encombrement Center-to-end		SCH 5S	SCH 10S	SCH 40S	SCH 80S
		C – mm	M – mm	† ép./W.T. mm masse/weight kg			
Pouces/Inches	D – mm	C – mm	M – mm				
1/2	21	25	25	1,65	2,11	2,77	3,73
				00,9	0,10	0,12	0,14
3/4	27	29	29	1,65	2,11	2,87	3,91
				0,10	0,13	0,17	0,20
1	33	38	38	1,65	2,77	3,38	4,55
				0,18	0,28	0,30	0,40
1 1/4	42	48	48	1,65	2,77	3,56	4,85
				0,35	0,50	0,60	0,70
1 1/2	48	57	57	1,65	2,77	3,68	5,08
				0,45	0,70	0,90	1,05
2	60	64	64	1,65	2,77	3,91	5,54
				0,55	0,85	1,30	1,60
2 1/2	73	76	76	2,11	3,05	5,16	7,01
				1,00	1,40	2,20	3,10
3	89	86	86	2,11	3,05	5,49	7,62
				1,55	1,80	3,30	4,40
3 1/2	102	95	95	2,11	3,05	5,74	8,08
				2,50	2,70	4,10	5,40
4	114	105	105	2,11	3,05	6,02	8,56
				3,30	3,50	5,30	7,70

Les masses indiquées sont approximatives.

(2) Ces dimensions ne sont pas reprises dans ASME B 36-19 M

(3) NPS 22" uniquement pour ASME B16-9

Diamètre Nominal Nominal Pipe Size (NPS)	Dia. extérieur au chanfrein Outside diameter at bevel	Encombrement Center-to-end		SCH 5S	SCH 10S	SCH 40S	SCH 80S
		C – mm	M – mm	† ép./W.T. mm masse/weight kg			
Pouces/Inches	D – mm	C – mm	M – mm				
5	141	124	124	2,77	3,40	6,55	9,53
				5,90	6,10	9,40	11,50
6	168	143	143	2,77	3,40	7,11	10,97
				7,80	8,10	11,00	13,60
8	219	178	178	2,77	3,76	8,18	12,70
				14,00	15,60	21,00	28,00
10	273	216	216	3,40	4,19	9,27	12,70
				25,00	27,00	36,00	50,00
12	324	254	254	3,96	4,57	9,53	12,70
				38,00	40,00	62,00	84,00
14	356	279	279	3,96	4,78	9,53	
				40,00	48,00	79,00	(2)
16	406	305	305	4,19	4,78	9,53	
				52,00	59,00	100,00	(2)
18	457	343	343	4,19	4,78	9,53	
				68,00	77,00	130,00	(2)
20	508	381	381	4,78	5,54	9,53	
				78,00	103,00	162,00	(2)
22 (3)	559	419	419	4,78	5,54		
24	610	432	432	5,54	6,35	9,53	
				90,00	155,00	225,00	(2)

Weights are approximate

(2) Those do not conform to ASME B 36-19 M

(3) NPS 22" only for ASME B 16-9



tés réduits

ASME B 16-9 – 1993
MSS-SP 43-1991

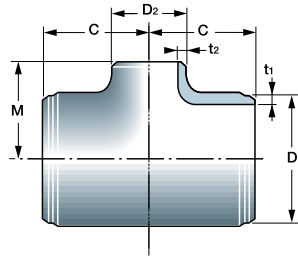

reducing outlet tees

ASME B 16-9 – 1993
MSS-SP 43-1991

Diamètre Nominal Nominal Pipe Size (NPS)	Dia. extérieur au chanfrein Outside diameter at bevel		Encombrement Center-to-end		SCH 5S	SCH 10S	SCH 40S	SCH 80S
					t ₁ ép./W.T. mm			
					t ₂ ép./W.T. mm			
Pouces/Inches	D – mm	C – mm	M – mm	masse/weight kg				
1/2 x 3/8 (3)	21	17	25	25	2,11	2,77	3,73	
					1,65	2,31	3,20	
1/2 x 1/4 (3)	21	14	25	25	0,09	0,10	0,13	
					2,11	2,77	3,73	
3/4 x 1/2	27	21	29	29	1,65	2,11	2,87	3,91
					1,65	2,11	2,77	3,73
3/4 x 3/8 (3)	27	17	29	29	0,11	0,13	0,15	0,19
					2,11	2,87	3,91	
1 x 3/4	33	27	38	38	1,65	2,77	3,38	4,55
					0,17	0,27	0,28	0,36
1 x 1/2	33	21	38	38	1,65	2,77	3,38	4,55
					1,65	2,11	2,77	3,73
1 1/4 x 1	42	33	48	48	0,16	0,26	0,27	0,35
					1,65	2,77	3,56	4,85
1 1/4 x 3/4	42	27	48	48	1,65	2,77	3,38	4,55
					0,31	0,46	0,53	0,34
1 1/4 x 1/2	42	21	48	48	1,65	2,77	3,56	4,85
					1,65	2,11	2,77	3,73
1 1/2 x 1 1/4	48	42	57	57	0,29	0,43	0,51	0,61
					1,65	2,77	3,68	5,08
1 1/2 x 1	48	33	57	57	1,65	2,77	3,56	4,85
					0,39	0,67	0,78	0,92
					1,65	2,77	3,68	5,08
					1,65	2,77	3,38	4,55
					0,38	0,64	0,76	0,90

Les masses indiquées sont approximatives.
(3) Uniquement pour ASME B16-9

Diamètre Nominal Nominal Pipe Size (NPS)	Dia. extérieur au chanfrein Outside diameter at bevel		Encombrement Center-to-end		SCH 5S	SCH 10S	SCH 40S	SCH 80S
					t ₁ ép./W.T. mm			
					t ₂ ép./W.T. mm			
Pouces/Inches	D – mm	C – mm	M – mm	masse/weight kg				
1 1/2 x 3/4	48	27	57	57	1,65	2,77	3,68	5,08
					1,65	2,11	2,87	3,91
1 1/2 x 1/2 (3)	48	21	57	57	0,37	0,62	0,74	0,88
					1,65	2,77	3,68	5,08
2 x 1 1/2	60	48	64	60	1,65	2,11	2,77	3,73
					0,36	0,61	0,73	0,86
2 x 1 1/4	60	42	64	57	1,65	2,77	3,91	5,54
					1,65	2,77	3,68	5,08
2 x 1	60	33	64	51	0,49	0,77	1,15	1,43
					1,65	2,77	3,91	5,54
2 x 3/4	60	27	64	44	1,65	2,77	3,56	4,85
					0,48	0,75	1,13	1,40
2 1/2 x 2	73	60	76	70	1,65	2,77	3,91	5,54
					1,65	2,77	3,38	4,55
2 1/2 x 1 1/2	73	48	76	67	0,47	0,73	1,10	1,37
					1,65	2,77	3,91	5,54
2 1/2 x 1	73	33	76	57	1,65	2,77	3,56	4,85
					0,46	0,71	1,08	1,35
					2,11	3,05	5,16	7,01
					1,65	2,77	3,91	5,54
					0,88	1,21	1,98	2,80
					2,11	3,05	5,16	7,01
					0,86	1,19	1,93	2,75
					1,65	2,77	3,68	5,08
					2,11	3,05	5,16	7,01
					0,84	1,17	1,89	2,70
					1,65	2,77	3,56	4,85
					2,11	3,05	5,16	7,01
					0,84	1,17	1,89	2,70
					2,11	3,05	5,16	7,01
					1,65	2,77	3,38	4,55
					2,11	3,05	5,16	7,01
					0,83	1,15	1,87	2,65

Weights are approximate
(3) Only for ASME B 16-9



tés réduits

ASME B 16-9 – 1993
MSS-SP 43-1991

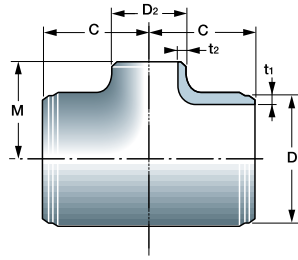

reducing outlet tees

ASME B 16-9 – 1993
MSS-SP 43-1991

Diamètre Nominal Nominal Pipe Size (NPS)	Dia. extérieur au chanfrein Outside diameter at bevel		Encombrement Center-to-end		SCH 5S	SCH 10S	SCH 40S	SCH 80S
					t ₁ ép./W.T. mm			
					t ₂ ép./W.T. mm			
Pouces/Inches	D – mm	C – mm	M – mm	masse/weight kg				
3 x 2 1/2	89	73	86	83	2,11	3,05	5,49	7,62
					2,11	3,05	5,16	7,01
					1,39	1,70	3,00	4,00
3 x 2	89	60	86	76	2,11	3,05	5,49	7,62
					1,65	2,77	3,91	5,54
					1,35	1,65	2,90	3,90
3 x 1 1/2	89	48	86	73	2,11	3,05	5,49	7,62
					1,65	2,77	3,68	5,08
					1,33	1,60	2,85	3,85
3 x 1 1/4 (3)	89	42	86	70	2,11	3,05	5,49	7,62
					1,65	2,77	3,56	4,85
					1,31	1,57	2,80	3,80
3 1/2 x 3	102	89	95	92	2,11	3,05	5,74	8,08
					2,11	3,05	5,49	7,62
					2,24	2,15	4,15	4,90
3 1/2 x 2 1/2	102	73	95	89	2,11	3,05	5,74	8,08
					2,11	3,05	5,16	7,01
					2,19	2,10	4,05	4,80
3 1/2 x 2	102	60	95	83	2,11	3,05	5,74	8,08
					1,65	2,77	3,91	5,54
					2,14	2,05	3,50	4,70
3 1/2 x 1 1/2	102	48	95	79	2,11	3,05	5,74	8,08
					1,65	2,77	3,68	5,08
					2,12	2,00	3,45	4,60
4 x 3 1/2	114	102	105	102	2,11	3,05	6,02	8,56
					2,11	3,05	5,74	8,08
					2,94	3,10	4,70	6,95
4 x 3	114	89	105	98	2,11	3,05	6,02	8,56
					2,11	3,05	5,49	7,62
					2,87	3,05	4,65	6,80
4 x 2 1/2	114	73	105	95	2,11	3,05	6,02	8,56
					2,11	3,05	5,16	7,01
					2,80	2,97	4,55	6,60

Les masses indiquées sont approximatives.
(3) Uniquement pour ASME B16-9

Diamètre Nominal Nominal Pipe Size (NPS)	Dia. extérieur au chanfrein Outside diameter at bevel		Encombrement Center-to-end		SCH 5S	SCH 10S	SCH 40S	SCH 80S
					t ₁ ép./W.T. mm			
					t ₂ ép./W.T. mm			
Pouces/Inches	D – mm	C – mm	M – mm	masse/weight kg				
4 x 2	114	60	105	89	2,11	3,05	6,02	8,56
					1,65	2,77	3,91	5,54
					2,77	2,93	4,50	6,55
4 x 1 1/2	114	48	105	86	2,11	3,05	6,02	8,56
					1,65	2,77	3,68	5,08
					2,74	2,90	4,45	6,50
5 x 4	141	114	124	117	2,77	3,40	6,55	9,53
					2,11	3,05	6,02	8,56
					5,30	5,50	8,50	10,20
5 x 3 1/2	141	102	124	114	2,77	3,40	6,55	9,53
					2,11	3,05	5,74	8,08
					5,18	5,35	8,30	10,00
5 x 3	141	89	124	111	2,77	3,40	6,55	9,53
					2,11	3,05	5,49	7,62
					5,10	5,25	8,10	9,75
5 x 2 1/2	141	73	124	108	2,77	3,40	6,55	9,53
					2,11	3,05	5,16	7,01
					5,00	5,20	8,00	9,65
5 x 2	141	60	124	105	2,77	3,40	6,55	9,53
					1,65	2,77	3,91	5,54
					4,95	5,10	7,90	9,50
6 x 5	168	141	143	137	2,77	3,40	7,11	10,97
					2,77	3,40	6,55	9,53
					7,00	7,25	12,30	12,20
6 x 4	168	114	143	130	2,77	3,40	7,11	10,97
					2,11	3,05	6,02	8,56
					6,85	7,10	12,10	12,00
6 x 3 1/2	168	102	143	127	2,77	3,40	7,11	10,97
					2,11	3,05	5,74	8,08
					6,70	6,95	12,00	11,70

Weights are approximate
(3) Only for ASME B 16-9



tés réduits

ASME B 16-9 – 1993
MSS-SP 43-1991

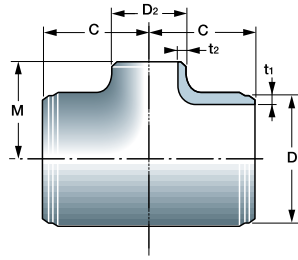

reducing outlet tees

ASME B 16-9 – 1993
MSS-SP 43-1991

Diamètre Nominal Nominal Pipe Size (NPS)	Dia. extérieur au chanfrein Outside diameter at bevel		Encombrement Center-to-end		SCH 5S	SCH 10S	SCH 40S	SCH 80S
					t ₁ ép./W.T. mm			
					t ₂ ép./W.T. mm			
Pouces/Inches	D – mm		C – mm	M – mm	masse/weight kg			
6 x 3	168	89	143	124	2,77	3,40	7,11	10,97
					2,11	3,05	5,49	7,62
6 x 2 1/2	168	73	143	121	6,65	6,85	11,90	11,50
					2,77	3,40	7,11	10,97
8 x 6	219	168	178	168	2,11	3,05	5,16	7,01
					6,60	6,75	11,70	11,40
8 x 5	219	141	178	162	2,77	3,76	8,18	12,70
					2,77	3,40	7,11	10,97
8 x 4	219	114	178	156	12,60	14,00	18,80	25,30
					2,77	3,76	8,18	12,70
8 x 3 1/2	219	102	178	152	2,77	3,40	6,55	9,53
					2,11	3,05	5,16	7,01
10 x 8	273	219	216	203	12,40	13,70	18,40	24,70
					2,77	3,76	8,18	12,70
10 x 6	273	168	216	194	2,11	3,05	6,02	8,56
					12,10	13,40	18,00	24,20
10 x 5	273	141	216	191	2,77	3,76	8,18	12,70
					2,11	3,05	5,74	8,08
10 x 4	273	114	216	184	11,90	13,30	17,80	23,90
					3,40	4,19	9,27	12,70
10 x 4	273	114	216	184	2,77	3,76	8,18	12,70
					22,40	24,10	31,80	44,80
10 x 4	273	114	216	184	3,40	4,19	9,27	12,70
					2,77	3,40	7,11	10,97
10 x 4	273	114	216	184	21,90	23,50	31,10	43,90
					3,40	4,19	9,27	12,70
10 x 4	273	114	216	184	2,77	3,40	6,55	9,53
					21,40	23,00	30,40	42,90
10 x 4	273	114	216	184	3,40	4,19	9,27	12,70
					2,11	3,05	6,02	8,56
10 x 4	273	114	216	184	21,20	22,70	30,00	42,40

Les masses indiquées sont approximatives.
(2) Ces dimensions ne sont pas reprises dans ASME B 36-19 M

Diamètre Nominal Nominal Pipe Size (NPS)	Dia. extérieur au chanfrein Outside diameter at bevel		Encombrement Center-to-end		SCH 5S	SCH 10S	SCH 40S (2)	SCH 80S
					t ₁ ép./W.T. mm			
					t ₂ ép./W.T. mm			
Pouces/Inches	D – mm		C – mm	M – mm	masse/weight kg			
12 x 10	324	273	254	241	3,96	4,57	9,53	12,70
					3,40	4,19	9,27	12,70
12 x 8	324	219	254	229	33,80	35,50	55,70	75,20
					3,96	4,57	9,53	12,70
12 x 6	324	168	254	219	2,77	3,76	8,18	12,70
					33,10	34,70	54,40	73,80
12 x 5	324	141	254	216	3,96	4,57	9,53	12,70
					2,77	3,40	7,11	10,97
14 x 12	356	324	279	270	32,30	33,90	53,50	72,00
					3,96	4,78	9,53	
14 x 10	356	273	279	257	3,96	4,57	9,53	
					36,30	43,60	71,10	
14 x 8	356	219	279	248	3,40	4,19	9,27	
					35,50	42,70	69,80	
14 x 6	356	168	279	238	3,96	4,78	9,53	
					2,77	3,76	8,18	
16 x 14	406	356	305	305	34,70	41,70	68,00	
					3,96	4,78	9,53	
16 x 12	406	324	305	295	4,19	4,78	9,53	
					2,77	3,40	7,11	
16 x 12	406	324	305	295	34,30	41,20	67,00	
					4,19	4,78	9,53	
16 x 12	406	324	305	295	3,96	4,57	9,53	
					46,70	53,00	90,00	
16 x 12	406	324	305	295	4,19	4,78	9,53	
					45,80	51,60	87,50	

Weights are approximate
(2) Those do not conform to ASME B 36-19 M



tés réduits

ASME B 16-9 – 1993
MSS-SP 43-1991

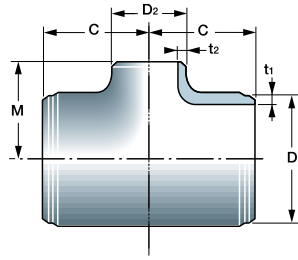

reducing outlet tees

ASME B 16-9 – 1993
MSS-SP 43-1991

Diamètre Nominal Nominal Pipe Size (NPS)	Dia. extérieur au chanfrein Outside diameter at bevel		Encombrement Center-to-end		SCH 5S	SCH 10S	SCH 40S (2)	SCH 80S
					t ₁ ép./W.T. mm			
					t ₂ ép./W.T. mm		masse/weight kg	
Pouces/Inches	D – mm	C – mm	M – mm					
16 x 10	406	273	305	283	4,19	4,78	9,53	
					3,40	4,19	9,27	
					44,80	50,70	85,50	
16 x 8	406	219	305	273	4,19	4,78	9,53	
					2,77	3,76	8,18	
					44,30	49,80	84,50	
16 x 6	406	168	305	264	4,19	4,78	9,53	
					2,77	3,40	7,11	
					43,80	49,40	83,50	
18 x 16	457	406	343	330	4,19	4,78	9,53	
					4,19	4,78	9,53	
					60,70	68,90	116,00	
18 x 14	457	356	343	330	4,19	4,78	9,53	
					3,96	4,78	9,53	
					59,30	67,00	114,00	
18 x 12	457	324	343	321	4,19	4,78	9,53	
					3,96	4,57	9,53	
					58,00	65,70	111,00	
18 x 10	457	273	343	308	4,19	4,78	9,53	
					3,40	4,19	9,27	
					57,00	64,80	110,00	
18 x 8	457	219	343	298	4,19	4,78	9,53	
					2,77	3,76	8,18	
					56,60	64,30	109,00	
20 x 18	508	457	381	368	4,78	5,54	9,53	
					4,19	4,78	9,53	
					69,80	93,00	146,00	
20 x 16	508	406	381	356	4,78	5,54	9,53	
					4,19	4,78	9,53	
					68,80	90,50	143,00	

Les masses indiquées sont approximatives.
(2) Ces dimensions ne sont pas reprises dans ASME B 36-19 M
(3) Uniquement dans ASME B16-9

Diamètre Nominal Nominal Pipe Size (NPS)	Dia. extérieur au chanfrein Outside diameter at bevel		Encombrement Center-to-end		SCH 5S	SCH 10S	SCH 40S (2)	SCH 80S
					t ₁ ép./W.T. mm			
					t ₂ ép./W.T. mm		masse/weight kg	
Pouces/Inches	D – mm	C – mm	M – mm					
20 x 14	508	356	381	356	4,78	5,54	9,53	
					3,96	4,78	9,53	
					66,60	89,00	140,00	
20 x 12	508	324	381	346	4,78	5,54	9,53	
					3,96	4,57	9,53	
					65,70	87,50	138,00	
20 x 10	508	273	381	333	4,78	5,54	9,53	
					3,40	4,19	9,27	
					64,80	86,50	136,00	
20 x 8	508	219	381	324	4,78	5,54	9,53	
					2,77	3,76	8,18	
					63,90	85,50	135,00	
22 x 20 (3)	559	508	419	406	4,78	5,54		
					4,78	5,54		
22 x 18 (3)	559	457	419	394	4,78	5,54		
					4,19	4,78		
22 x 16 (3)	559	406	419	381	4,78	5,54		
					4,19	4,78		
22 x 14 (3)	559	356	419	381	4,78	5,54		
					3,96	4,78		
22 x 12 (3)	559	324	419	371	4,78	5,54		
					3,96	4,57		
22 x 10 (3)	559	273	419	359	4,78	5,54		
					3,40	4,19		

Weights are approximate
(2) Those do not conform to ASME B 36-19 M
(3) Only in ASME B 16-9



tés réduits

reducing outlet tees

ASME B 16.9 - 1993
MSS-SP 43-1991

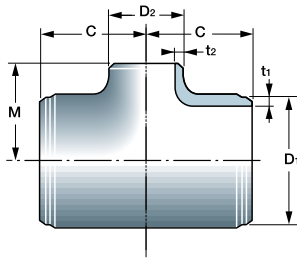

Diamètre Nominal Nominal Pipe Size (NPS)	Dia. extérieur au chanfrein Outside diameter at bevel		Encombrement Center-to-end		SCH 5S	SCH 10S	SCH 40S (2)	SCH 80S
	D - mm		C - mm	M - mm	t ₁ ép./W.T. mm		t ₂ ép./W.T. mm	
Pouces/Inches					masse/weight kg			
24 x 22 (3)	610	559	432	432	5,54	6,35		
					4,78	5,54		
24 x 20	610	508	432	432	5,54	6,35	9,53	
					4,78	5,54	9,53	
					121,00	140,00	207,00	
24 x 18	610	457	432	419	5,54	6,35	9,53	
					4,19	4,78	9,53	
					119,00	137,00	198,00	
24 x 16	610	406	432	406	5,54	6,35	9,53	
					4,19	4,78	9,53	
					116,00	134,00	194,00	
24 x 14	610	356	432	406	5,54	6,35	9,53	
					3,96	4,78	9,53	
					115,00	132,00	191,00	
24 x 12	610	324	432	397	5,54	6,35	9,53	
					3,96	4,57	9,53	
					113,00	130,00	189,00	
24 x 10	610	273	432	384	5,54	6,35	9,53	
					3,40	4,19	9,27	
					112,00	129,00	187,00	

Les masses indiquées sont approximatives.

(2) Ces dimensions ne sont pas reprises dans ASME B 36-19 M

(3) Uniquement dans ASME B16-9

Weights are approximate

(2) Those do not conform to ASME B 36-19 M

(3) Only in ASME B 16-9



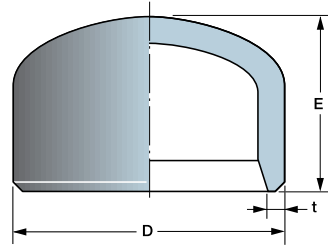

Diamètre Nominal Nominal Pipe Size (NPS)	Dia. extérieur au chanfrein Outside diameter at bevel	Hauteur Length	SCH 5S	SCH 10S	SCH 40S	SCH 80S
			t ép./W.T. mm masse/weight kg			
Pouces/Inches	D – mm	E – mm				
1/2	21	25	1,65	2,11	2,77	3,73
			0,04	0,04	0,05	0,06
3/4	27	25	1,65	2,11	2,87	3,91
			0,05	0,06	0,06	0,07
1	33	38	1,65	2,77	3,38	4,55
			0,08	0,09	0,13	0,14
1 1/4	42	38	1,65	2,77	3,56	4,85
			0,09	0,13	0,17	0,18
1 1/2	48	38	1,65	2,77	3,68	5,08
			0,10	0,14	0,23	0,25
2	60	38	1,65	2,77	3,91	5,54
			0,16	0,20	0,27	0,35
2 1/2	73	38	2,11	3,05	5,16	7,01
			0,25	0,30	0,45	0,50
3	89	51	2,11	3,05	5,49	7,62
			0,40	0,45	0,70	0,85
3 1/2	102	64	2,11	3,05	5,74	8,08
			0,55	0,60	1,05	1,15
4	114	64	2,11	3,05	6,02	8,56
			0,60	0,65	1,20	1,60

Les masses indiquées sont approximatives.

Note : La forme de ces caps pour ASME B 16-9 sera ellipsoïdale et conforme aux exigences du code «ASME Boiler and Pressure Vessel»

(2) Ces dimensions ne sont pas reprises dans ASME B 36-19 M

(3) Uniquement dans ASME B16-9



Diamètre Nominal Nominal Pipe Size (NPS)	Dia. extérieur au chanfrein Outside diameter at bevel	Hauteur Length	SCH 5S	SCH 10S	SCH 40S	SCH 80S
			t ép./W.T. mm masse/weight kg			
Pouces/Inches	D – mm	E – mm				
5	141	76	2,77	3,40	6,55	9,53
			0,90	1,05	1,90	2,60
6	168	89	2,77	3,40	7,11	10,97
			1,25	1,40	3,20	4,50
8	219	102	2,77	3,76	8,18	12,70
			2,10	2,50	5,70	7,40
10	273	127	3,40	4,19	9,27	12,70
			4,30	4,90	9,20	12,40
12	324	152	3,96	4,57	9,53	12,70
			6,40	7,00	13,00	16,60
14	356	165	3,96	4,78	9,53	
			7,80	8,50	16,50	(2)
16	406	178	4,19	4,78	9,53	
			13,50	14,50	22,00	(2)
18	457	203	4,19	4,78	9,53	
			17,20	18,00	27,00	(2)
20	508	229	4,78	5,54	9,53	
			25,00	27,50	34,00	(2)
22 (3)	559	254	4,78	5,54		
24	610	267	5,54	6,35	9,53	
			34,00	35,00	45,00	(2)

Weights are approximate

Note : The shape of these caps for ASME B 16-9 shall be ellipsoidal and shall conform to the shape requirements as given in the ASME Boiler and Pressure Vessel Code.

(2) Those do not conform to ASME B 36-19 M

(3) Only in ASME B 16-9



réductions concentriques et excentriques

ASME B 16-9 – 1993
MSS-SP 43-1991

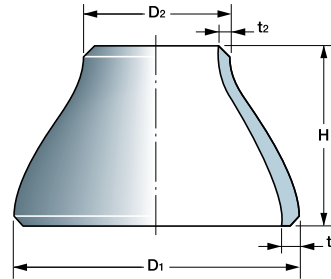

concentric and eccentric reducers

ASME B 16-9 – 1993
MSS-SP 43-1991

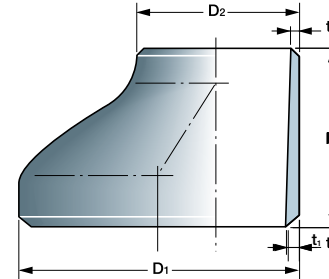

Diamètre Nominal Nominal Pipe Size (NPS)	Dia. extérieur au chanfrein Outside diameter at bevel		Longueur End-to-end length	SCH 5S	SCH 10S	SCH 40S	SCH 80S
	D – mm			H – mm	t ₁ ép./W.T. mm	t ₂ ép./W.T. mm	masse/weight kg
3/4 x 1/2	27	21	38	1,65	2,11	2,87	3,91
				1,65	2,11	2,77	3,73
				0,08	0,10	0,13	0,18
3/4 x 3/8 (3)	27	17	38		2,11	2,87	3,91
					1,65	2,31	3,20
					0,09	0,12	0,17
1 x 3/4	33	27	51	1,65	2,77	3,38	4,55
				1,65	2,11	2,87	3,91
				0,08	0,13	0,16	0,21
1 x 1/2	33	21	51	1,65	2,77	3,38	4,55
				1,65	2,11	2,77	3,73
				0,07	0,12	0,15	0,19
1 x 3/8 (4)	33	17	51		2,77	3,38	4,55
					1,65	2,31	3,20
1 1/4 x 1	42	33	51	1,65	2,77	3,56	4,85
				1,65	2,77	3,38	4,55
				0,10	0,18	0,22	0,27
1 1/4 x 3/4	42	27	51	1,65	2,77	3,56	4,85
				1,65	2,11	2,87	3,91
				0,10	0,17	0,21	0,25
1 1/4 x 1/2	42	21	51	1,65	2,77	3,56	4,85
				1,65	2,11	2,77	3,73
				0,09	0,16	0,20	0,23
1 1/2 x 1 1/4	48	42	64	1,65	2,77	3,68	5,08
				1,65	2,77	3,56	4,85
				0,12	0,21	0,28	0,36
1 1/2 x 1	48	33	64	1,65	2,77	3,68	5,08
				1,65	2,77	3,38	4,55
				0,11	0,20	0,26	0,33

Les masses indiquées sont approximatives.
(3) Uniquement dans ASME B16-9
(4) Uniquement dans MSS-SP 43

Diamètre Nominal Nominal Pipe Size (NPS)	Dia. extérieur au chanfrein Outside diameter at bevel		Longueur End-to-end length	SCH 5S	SCH 10S	SCH 40S	SCH 80S
	D – mm			H – mm	t ₁ ép./W.T. mm	t ₂ ép./W.T. mm	masse/weight kg
1 1/2 x 3/4	48	27	64	1,65	2,77	3,68	5,08
				1,65	2,11	2,87	3,91
				0,11	0,18	0,24	0,32
1 1/2 x 1/2	48	21	64	1,65	2,77	3,68	5,08
				1,65	2,11	2,77	3,73
				0,10	0,17	0,22	0,31
2 x 1 1/2	60	48	76	1,65	2,77	3,91	5,54
				1,65	2,77	3,68	5,08
				0,19	0,31	0,45	0,59
2 x 1 1/4	60	42	76	1,65	2,77	3,91	5,54
				1,65	2,77	3,56	4,85
				0,18	0,30	0,43	0,57
2 x 1	60	33	76	1,65	2,77	3,91	5,54
				1,65	2,77	3,38	4,55
				0,17	0,28	0,40	0,53
2 x 3/4	60	27	76	1,65	2,77	3,91	5,54
				1,65	2,11	2,87	3,91
				0,15	0,25	0,36	0,50
2 1/2 x 2	73	60	89	2,11	3,05	5,16	7,01
				1,65	2,77	3,91	5,54
				0,32	0,47	0,80	1,05
2 1/2 x 1 1/2	73	48	89	2,11	3,05	5,16	7,01
				1,65	2,77	3,68	5,08
				0,30	0,44	0,76	0,94
2 1/2 x 1 1/4	73	42	89	2,11	3,05	5,16	7,01
				1,65	2,77	3,56	4,85
				0,29	0,43	0,73	0,90
2 1/2 x 1	73	33	89	2,11	3,05	5,16	7,01
				1,65	2,77	3,38	4,55
				0,25	0,38	0,64	0,87

Weights are approximate
(3) Only in ASME B 16-9
(4) Only in MSS-SP 43



réductions concentriques et excentriques

ASME B 16-9 – 1993
MSS-SP 43-1991

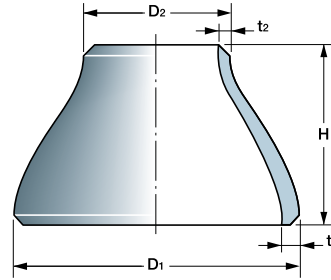

concentric and eccentric reducers

ASME B 16-9 – 1993
MSS-SP 43-1991

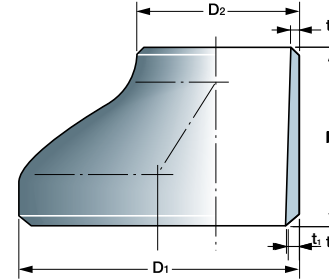

Diamètre Nominal Nominal Pipe Size (NPS)	Dia. extérieur au chanfrein Outside diameter at bevel		Longueur End-to-end length	SCH 5S	SCH 10S	SCH 40S	SCH 80S
	D – mm			H – mm	t_1 ép./W.T. mm	t_2 ép./W.T. mm	masse/weight kg
3 x 2 1/2	89	73	89	2,11	3,05	5,49	7,62
				2,11	3,05	5,16	7,01
				0,41	0,59	1,10	1,49
3 x 2	89	60	89	2,11	3,05	5,49	7,62
				1,65	2,77	3,91	5,54
				0,38	0,55	1,00	1,29
3 x 1 1/2	89	48	89	2,11	3,05	5,49	7,62
				1,65	2,77	3,68	5,08
				0,35	0,51	0,94	1,20
3 x 1 1/4	89	42	89	2,11	3,05	5,49	7,62
				1,65	2,77	3,56	4,85
				0,32	0,47	0,85	1,15
3 1/2 x 3	102	89	102	2,11	3,05	5,74	8,08
				2,11	3,05	5,49	7,62
				0,54	0,80	1,50	2,00
3 1/2 x 2 1/2	102	73	102	2,11	3,05	5,74	8,08
				2,11	3,05	5,16	7,01
				0,52	0,77	1,46	1,90
3 1/2 x 2	102	60	102	2,11	3,05	5,74	8,08
				1,65	2,77	3,91	5,54
				0,48	0,71	1,35	1,75
3 1/2 x 1 1/2	102	48	102	2,11	3,05	5,74	8,08
				1,65	2,77	3,68	5,08
				0,45	0,66	1,25	1,65
3 1/2 x 1 1/4	102	42	102	2,11	3,05	5,74	8,08
				1,65	2,77	3,56	4,85
				0,42	0,62	1,20	1,60
4 x 3 1/2	114	102	102	2,11	3,05	6,02	8,56
				2,11	3,05	5,74	8,08
				0,63	0,90	1,80	2,40
4 x 3	114	89	102	2,11	3,05	6,02	8,56
				2,11	3,05	5,49	7,62
				0,61	0,87	1,75	2,30

Les masses indiquées sont approximatives.

Diamètre Nominal Nominal Pipe Size (NPS)	Dia. extérieur au chanfrein Outside diameter at bevel		Longueur End-to-end length	SCH 5S	SCH 10S	SCH 40S	SCH 80S
	D – mm			H – mm	t_1 ép./W.T. mm	t_2 ép./W.T. mm	masse/weight kg
4 x 2 1/2	114	73	102	2,11	3,05	6,02	8,56
				2,11	3,05	5,16	7,01
				0,83	1,65	2,20	
4 x 2	114	60	102	2,11	3,05	6,02	8,56
				1,65	2,77	3,91	5,54
				0,78	1,60	1,95	
4 x 1 1/2	114	48	102	2,11	3,05	6,02	8,56
				1,65	2,77	3,68	5,08
				0,68	1,35	1,90	
5 x 4	141	114	127	2,77	3,40	6,55	9,53
				2,11	3,05	6,02	8,56
				1,50	3,00	4,10	
5 x 3 1/2	141	102	127	2,77	3,40	6,55	9,53
				2,11	3,05	5,74	8,08
				1,48	2,90	4,00	
5 x 3	141	89	127	2,77	3,40	6,55	9,53
				2,11	3,05	5,49	7,62
				1,45	2,80	3,90	
5 x 2 1/2	141	73	127	2,77	3,40	6,55	9,53
				2,11	3,05	5,16	7,01
				1,40	2,70	3,60	
5 x 2	141	60	127	2,77	3,40	6,55	9,53
				1,65	2,77	3,91	5,54
				1,30	2,50	3,30	
6 x 5	168	141	140	2,77	3,40	7,11	10,97
				2,77	3,40	6,55	9,53
				2,00	4,30	6,20	
6 x 4	168	114	140	2,77	3,40	7,11	10,97
				2,11	3,05	6,02	8,56
				1,95	4,10	5,95	
6 x 3 1/2	168	102	140	2,77	3,40	7,11	10,97
				2,11	3,05	5,74	8,08
				1,90	4,05	5,75	

Weights are approximate



réductions concentriques et excentriques

ASME B 16-9 – 1993
MSS-SP 43-1991

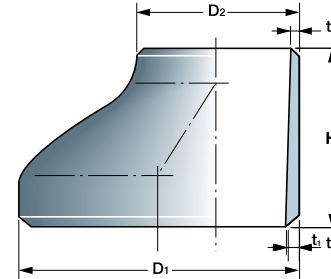
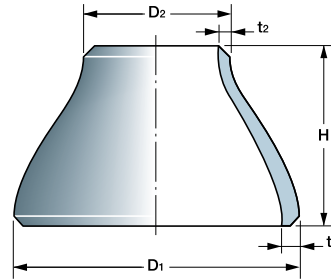

concentric and eccentric reducers

ASME B 16-9 – 1993
MSS-SP 43-1991

Diamètre Nominal Nominal Pipe Size (NPS)	Dia. extérieur au chanfrein Outside diameter at bevel		Longueur End-to-end length	SCH 5S	SCH 10S	SCH 40S	SCH 80S
	D – mm			H – mm	t ₁ ép./W.T. mm	t ₂ ép./W.T. mm	masse/weight kg
6 x 3	168	89	140	2,77	3,40	7,11	10,97
				2,11	3,05	5,49	7,62
				1,50	1,80	4,00	5,50
6 x 2 1/2	168	73	140	2,77	3,40	7,11	10,97
				2,11	3,05	5,16	7,01
				1,45	1,55	3,80	4,90
8 x 6	219	168	152	2,77	3,76	8,18	12,70
				2,77	3,40	7,11	10,97
				2,30	3,20	6,90	10,10
8 x 5	219	141	152	2,77	3,76	8,18	12,70
				2,77	3,40	6,55	9,53
				2,20	3,10	6,70	9,70
				2,77	3,76	8,18	12,70
8 x 4	219	114	152	2,11	3,05	6,02	8,56
				2,15	3,00	6,50	9,20
				2,77	3,76	8,18	12,70
8 x 3 1/2	219	102	152	2,11	3,05	5,74	8,08
				2,10	2,95	6,40	8,00
				3,40	4,19	9,27	12,70
10 x 8	273	219	178	2,77	3,76	8,18	12,70
				4,20	5,20	11,50	15,60
				3,40	4,19	9,27	12,70
10 x 6	273	168	178	2,77	3,40	7,11	10,97
				4,00	5,00	11,10	14,80
				3,40	4,19	9,27	12,70
10 x 5	273	141	178	2,77	3,40	6,55	9,53
				3,90	4,90	10,80	14,20
				3,40	4,19	9,27	12,70
10 x 4	273	114	178	2,11	3,05	6,02	8,56
				3,80	4,70	10,50	12,50

Les masses indiquées sont approximatives.

(2) Ces dimensions ne sont pas reprises dans ASME B 36-19 M

Diamètre Nominal Nominal Pipe Size (NPS)	Dia. extérieur au chanfrein Outside diameter at bevel		Longueur End-to-end length	SCH 5S	SCH 10S	SCH 40S	SCH 80S
	D – mm			H – mm	t ₁ ép./W.T. mm	t ₂ ép./W.T. mm	masse/weight kg
12 x 10	324	273	203	3,96	4,57	9,53	12,70
				3,40	4,19	9,27	12,70
				6,80	8,00	16,60	21,60
12 x 8	324	219	203	3,96	4,57	9,53	12,70
				2,77	3,76	8,18	12,70
				6,50	7,70	16,00	20,90
12 x 6	324	168	203	3,96	4,57	9,53	12,70
				2,77	3,40	7,11	10,97
				6,30	7,40	15,50	20,10
12 x 5	324	141	203	3,96	4,57	9,53	12,70
				2,77	3,40	6,55	9,53
				6,20	7,30	15,20	19,40
				3,96	4,78	9,53	
14 x 12	256	324	330	3,96	4,57	9,53 (2)	
				12,50	15,30	30,50	
				3,96	4,78	9,53	
14 x 10	356	273	330	3,40	4,19	9,27 (2)	
				11,80	14,40	28,80	
				3,96	4,78	9,53	
14 x 8	356	219	330	2,77	3,76	8,18 (2)	
				11,40	13,90	27,70	
				3,96	4,78	9,53	
14 x 6	356	168	330	2,77	3,40	7,11 (2)	
				10,70	13,10	26,30	
				3,96	4,78	9,53	
16 x 14	406	356	356	4,19	4,78	9,53	
				3,96	4,78	9,53 (2)	
				16,50	18,80	37,60	
16 x 12	406	324	356	4,19	4,78	9,53	
				3,96	4,57	9,53 (2)	
				16,10	18,30	36,70	

Weights are approximate

(2) Those do not conform to ASME B 36-19 M



réductions concentriques et excentriques

ASME B 16-9 – 1993
MSS-SP 43-1991

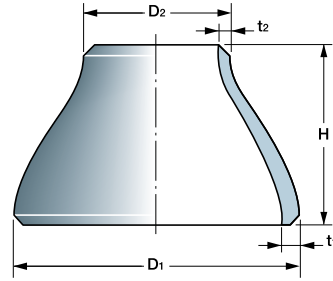

concentric and eccentric reducers

ASME B 16-9 – 1993
MSS-SP 43-1991

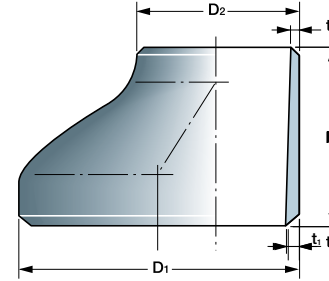

Diamètre Nominal Nominal Pipe Size (NPS)	Dia. extérieur au chanfrein Outside diameter at bevel		Longueur End-to-end length	SCH 5S	SCH 10S	SCH 40S	SCH 80S
	D – mm			H – mm	t_1 ép./W.T. mm	t_2 ép./W.T. mm	masse/weight kg
16 x 10	406	273	356	4,19	4,78	9,53	
				3,40	4,19	9,27 (2)	
				15,60	17,70	35,40	
16 x 8	406	219	356	4,19	4,78	9,53	
				2,77	3,76	8,18 (2)	
				14,60	16,70	33,30	
18 x 16	457	406	381	4,19	4,78	9,53	
				4,19	4,78	9,53 (2)	
				19,80	22,50	44,90	
18 x 14	457	356	381	4,19	4,78	9,53	
				3,96	4,78	9,53 (2)	
				19,20	21,90	43,70	
18 x 12	457	324	381	4,19	4,78	9,53	
				3,96	4,57	9,53 (2)	
				18,90	21,40	42,90	
18 x 10	457	273	381	4,19	4,78	9,53	
				3,40	4,19	9,27 (2)	
				18,50	21,00	42,00	
20 x 18	508	457	508	4,78	5,54	9,53	
				4,19	4,78	9,53 (2)	
				30,00	33,00	67,00	
20 x 16	508	406	508	4,78	5,54	9,53	
				4,19	4,78	9,53 (2)	
				29,00	32,00	65,00	
20 x 14	508	356	508	4,78	5,54	9,53	
				3,96	4,78	9,53 (2)	
				28,00	31,00	61,00	
20 x 12	508	324	508	4,78	5,54	9,53	
				3,96	4,57	9,53	
				27,00	30,00	60,00	

Les masses indiquées sont approximatives.
(2) Ces dimensions ne sont pas reprises dans ASME B 36-19 M
(3) Uniquement dans ASME B 16-9

Diamètre Nominal Nominal Pipe Size (NPS)	Dia. extérieur au chanfrein Outside diameter at bevel		Longueur End-to-end length	SCH 5S	SCH 10S	SCH 40S	SCH 80S
	D – mm			H – mm	t_1 ép./W.T. mm	t_2 ép./W.T. mm	masse/weight kg
22 x 20 (3)	559	508	508	4,78	5,54		
				4,78	5,54		
22 x 18 (3)	559	457	508	4,78	5,54		
				4,19	4,78		
22 x 16 (3)	559	406	508	4,78	5,54		
				4,19	4,78		
22 x 14 (3)	559	356	508	4,78	5,54		
				3,96	4,78		
24 x 22 (3)	610	559	508	5,54	6,35		
				4,78	5,54		
24 x 20	610	508	508	5,54	6,35	9,53	
				4,78	5,54	9,53	
24 x 18	610	457	508	41,50	47,00	79,00	
				5,54	6,35	9,53	
24 x 16	610	406	508	4,19	4,78	9,53	
				40,00	45,00	76,00	
				5,54	6,35	9,53	
				4,19	4,78	9,53	
				39,00	44,00	75,00	

Weights are approximate
(2) Those do not conform to ASME B 36-19 M
(3) Only in ASME B 16-9



collets «stub end» types A et B

ASME B 16-9 – 1993
MSS-SP 43-1991

Type A pour bride tournante (5)
Type B pour bride slip-on (5)

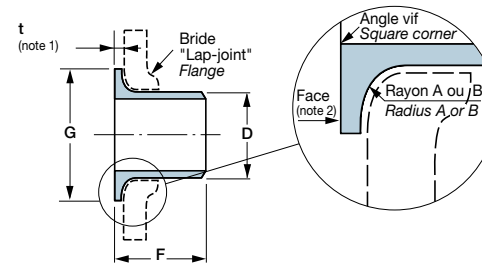
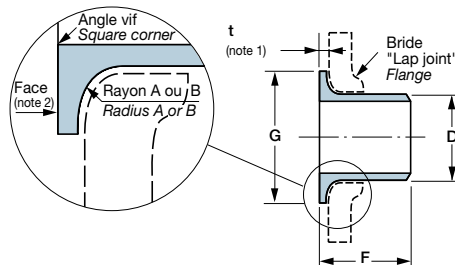

lap joint stub ends types A and B

ASME B 16-9 – 1993
MSS-SP 43-1991

Type A for lap joint flange (5)
Type B for slip-on flange (5)

Diamètre Nominal Nominal Pipe Size (NPS)	Dia. extérieur nominal au chanfrein Nominal outside diameter at bevel	Longueur (4) Length (4)		Diamètre nominal et maxi du collet Nominal and maxi diameter of lap	Rayon du congé Radius of fillet		Série courte (4) Short length (4)		
		Court Short	Long Long		A – mm nom./maxi	B – mm maxi	SCH 5S	SCH 10S	SCH 40S
							† ép./W.T. masse/weight	mm kg	
Pouces/Inches	D – mm	F – mm		G – mm					
1/2	21	51	76	35	3	0,8	1,65	2,11	2,77
							0,05	0,06	0,08
3/4	27	51	76	43	3	0,8	1,65	2,11	2,87
							0,06	0,07	0,10
1	33	51	102	51	3	0,8	1,65	2,77	3,38
							0,08	0,13	0,16
1 1/4	42	51	102	64	5	0,8	1,65	2,77	3,56
							0,11	0,18	0,23
1 1/2	48	51	102	73	6	0,8	1,65	2,77	3,68
							0,13	0,20	0,28
2	60	64	152	92	8	0,8	1,65	2,77	3,91
							0,20	0,34	0,47
2 1/2	73	64	152	105	8	0,8	2,11	3,05	5,16
							0,31	0,45	0,75
3	89	64	152	127	10	0,8	2,11	3,05	5,49
							0,40	0,57	1,00
3 1/2	102	76	152	140	10	0,8	2,11	3,05	5,74
							0,55	0,75	1,40
4	114	76	152	157	11	0,8	2,11	3,05	6,02
							0,65	0,90	1,70

Les masses indiquées sont approximatives.

Notes :

- 1 – L'épaisseur minimale du collet T ne doit pas être inférieure à l'épaisseur nominale du tube.
- 2 – Les faces devront avoir des stries concentriques ou spirales.
- 3 – NPS 22" uniquement dans ASME B 16-9.

- 4 – La longueur «courte» est la seule dimension dans MSS-SP 43 et en option dans ASME B 16-9. La longueur «longue» n'est que dans l'ASME B 16-9 et est le standard de cette norme (longueur «courte» en option).
- 5 – Type A : conforme à ASME B 16-9 et MSS-SP 43
Type B : uniquement dans MSS-SP 43.

Diamètre Nominal Nominal Pipe Size (NPS)	Dia. extérieur nominal au chanfrein Nominal outside diameter at bevel	Longueur (4) Length (4)		Diamètre nominal et maxi du collet Nominal and maxi diameter of lap	Rayon du congé Radius of fillet		Série courte (4) Short length (4)		
		Court Short	Long Long		A – mm nom./maxi	B – mm maxi	SCH 5S	SCH 10S	SCH 40S
							† ép./W.T. masse/weight	mm kg	
Pouces/Inches	D – mm	F – mm		G – mm					
5	141	76	203	186	11	1,6	2,77	3,40	6,55
							1,00	1,25	2,30
6	168	89	203	216	13	1,6	2,77	3,40	7,11
							1,30	1,60	3,40
8	219	102	203	270	13	1,6	2,77	3,76	8,18
							2,00	2,70	5,70
10	273	127	254	324	13	1,6	3,40	4,19	9,27
							3,60	4,40	9,60
12	324	152	254	381	13	1,6	3,96	4,57	9,53
							5,90	6,70	13,80
14	356	152	305	413	13	1,6	3,96	4,78	
							6,40	7,70	
16	406	152	305	470	13	1,6	4,19	4,78	
							7,90	9,00	
18	457	152	305	533	13	1,6	4,19	4,78	
							9,20	10,50	
20	508	152	305	584	13	1,6	4,78	5,54	
							11,70	13,50	
22 (3)	559	152	305	641	13	1,6	4,78	5,54	
24	610	152	305	692	13	1,6	5,54	6,35	
							16,50	18,90	

Weights are approximate

Notes :

- 1 – The minimum lap thickness T shall not be less than nominal pipe wall thickness.
- 2 – Contact faces of stub ends shall have a modified spiral or concentric serration.
- 3 – NPS 22" only in ASME B 16-9.

- 4 – The short pattern is the standard in MSS-SP 43 and shall be specified by the purchaser in ASME B 16-9. In ASME B 16-9 the long pattern shall be the standard when not specified by the purchaser. The short pattern shall be specified by the purchaser.
- 5 – Type A : conforme à ASME B 16-9 et MSS-SP 43
Type B : only in MSS-SP 43.

